

# Pioneer

AUDIO/VIDEO MULTI-CHANNEL RECEIVER

# VSX-40

# ELITE

Register your product on

<http://www.pioneerelectronics.com> (US)

<http://www.pioneerelectronics.ca> (Canada)

- **Protect your new investment**

The details of your purchase will be on file for reference in the event of an insurance claim such as loss or theft.

- **Receive free tips, updates and service bulletins on your new product**

- **Improve product development**

Your input helps us continue to design products that meet your needs.

- **Receive a free Pioneer newsletter**

Registered customers can opt in to receive a monthly newsletter.

Operating Instructions

## IMPORTANT



The lightning flash with arrowhead symbol, within an equilateral triangle, is intended to alert the user to the presence of uninsulated "dangerous voltage" within the product's enclosure that may be of sufficient magnitude to constitute a risk of electric shock to persons.

### CAUTION

**RISK OF ELECTRIC SHOCK  
DO NOT OPEN**

#### CAUTION:

TO PREVENT THE RISK OF ELECTRIC SHOCK, DO NOT REMOVE COVER (OR BACK). NO USER-SERVICEABLE PARTS INSIDE. REFER SERVICING TO QUALIFIED SERVICE PERSONNEL.



The exclamation point within an equilateral triangle is intended to alert the user to the presence of important operating and maintenance (servicing) instructions in the literature accompanying the appliance.

D3-4-2-1-1\_A1\_En

## VENTILATION CAUTION

When installing this unit, make sure to leave space around the unit for ventilation to improve heat radiation (at least 40 cm at top, 20 cm at rear, and 20 cm at each side).

## WARNING

Slots and openings in the cabinet are provided for ventilation to ensure reliable operation of the product, and to protect it from overheating. To prevent fire hazard, the openings should never be blocked or covered with items (such as newspapers, table-cloths, curtains) or by operating the equipment on thick carpet or a bed.

D3-4-2-1-7b\*\_A1\_En

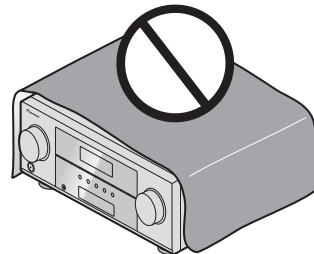

### NOTE:

This equipment has been tested and found to comply with the limits for a Class B digital device, pursuant to Part 15 of the FCC Rules. These limits are designed to provide reasonable protection against harmful interference in a residential installation. This equipment generates, uses, and can radiate radio frequency energy and, if not installed and used in accordance with the instructions, may cause harmful interference to radio communications. However, there is no guarantee that interference will not occur in a particular installation. If this equipment does cause harmful interference to radio or television reception, which can be determined by turning the equipment off and on, the user is encouraged to try to correct the interference by one or more of the following measures:

- Reorient or relocate the receiving antenna.
- Increase the separation between the equipment and receiver.
- Connect the equipment into an outlet on a circuit different from that to which the receiver is connected.
- Consult the dealer or an experienced radio/TV technician for help.

D8-10-1-2\_A1\_En

### Information to User

Alterations or modifications carried out without appropriate authorization may invalidate the user's right to operate the equipment.

D8-10-2\_A1\_En

## WARNING

This equipment is not waterproof. To prevent a fire or shock hazard, do not place any container filled with liquid near this equipment (such as a vase or flower pot) or expose it to dripping, splashing, rain or moisture.

D3-4-2-1-3\_A1\_En

## WARNING

To prevent a fire hazard, do not place any naked flame sources (such as a lighted candle) on the equipment.

D3-4-2-1-7a\_A1\_En

## WARNING

*Before plugging in for the first time, read the following section carefully.*

**The voltage of the available power supply differs according to country or region. Be sure that the power supply voltage of the area where this unit will be used meets the required voltage (e.g., 230 V or 120 V) written on the rear panel.**

D3-4-2-1-4\*\_A1\_En

## Operating Environment

Operating environment temperature and humidity: +5 °C to +35 °C (+41 °F to +95 °F); less than 85 %RH (cooling vents not blocked)

Do not install this unit in a poorly ventilated area, or in locations exposed to high humidity or direct sunlight (or strong artificial light)

D3-4-2-1-7c\*\_A1\_En

### Caution

To prevent fire hazard, the Class 2 Wiring Cable should be used for connection with speaker, and should be routed away from hazards to avoid damage to the insulation of the cable.

D3-7-13-67\*\_A1\_En

# IMPORTANT SAFETY INSTRUCTIONS

- 1) Read these instructions.
- 2) Keep these instructions.
- 3) Heed all warnings.
- 4) Follow all instructions.
- 5) Do not use this apparatus near water.
- 6) Clean only with dry cloth.
- 7) Do not block any ventilation openings. Install in accordance with the manufacturer's instructions.
- 8) Do not install near any heat sources such as radiators, heat registers, stoves, or other apparatus (including amplifiers) that produce heat.
- 9) Do not defeat the safety purpose of the polarized or grounding-type plug. A polarized plug has two blades with one wider than the other. A grounding type plug has two blades and a third grounding prong. The wide blade or the third prong are provided for your safety. If the provided plug does not fit into your outlet, consult an electrician for replacement of the obsolete outlet.
- 10) Protect the power cord from being walked on or pinched particularly at plugs, convenience receptacles, and the point where they exit from the apparatus.

D3-4-2-1a\_A1\_En

If the AC plug of this unit does not match the AC outlet you want to use, the plug must be removed and appropriate one fitted. Replacement and mounting of an AC plug on the power supply cord of this unit should be performed only by qualified service personnel. If connected to an AC outlet, the cut-off plug can cause severe electrical shock. Make sure it is properly disposed of after removal. The equipment should be disconnected by removing the mains plug from the wall socket when left unused for a long period of time (for example, when on vacation).

D3-4-2-1a\_A1\_En

- 11) Only use attachments/accessories specified by the manufacturer.
- 12) Use only with the cart, stand, tripod, bracket, or table specified by the manufacturer, or sold with the apparatus. When a cart is used, use caution when moving the cart/apparatus combination to avoid injury from tip-over.



- 13) Unplug this apparatus during lightning storms or when unused for long periods of time.
- 14) Refer all servicing to qualified service personnel. Servicing is required when the apparatus has been damaged in any way, such as power-supply cord or plug is damaged, liquid has been spilled or objects have fallen into the apparatus, the apparatus has been exposed to rain or moisture, does not operate normally, or has been dropped.

D3-7-13-69\_En

## CAUTION

The **STANDBY/ON** switch on this unit will not completely shut off all power from the AC outlet. Since the power cord serves as the main disconnect device for the unit, you will need to unplug it from the AC outlet to shut down all power. Therefore, make sure the unit has been installed so that the power cord can be easily unplugged from the AC outlet in case of an accident. To avoid fire hazard, the power cord should also be unplugged from the AC outlet when left unused for a long period of time (for example, when on vacation).

D3-4-2-2a\*\_A1\_En

This Class B digital apparatus complies with Canadian ICES-003.

D8-10-1-3\_A1\_En

## CAUTION

This product satisfies FCC regulations when shielded cables and connectors are used to connect the unit to other equipment. To prevent electromagnetic interference with electric appliances such as radios and televisions, use shielded cables and connectors for connections.

D8-10-3a\_A1\_En

## IMPORTANT NOTICE

THE MODEL NUMBER AND SERIAL NUMBER OF THIS EQUIPMENT ARE ON THE REAR OR BOTTOM. RECORD THESE NUMBERS ON YOUR ENCLOSED WARRANTY CARD AND KEEP IN A SAFE PLACE FOR FUTURE REFERENCE.

D36-AP9-1\_A1\_En

**WARNING:** Handling the cord on this product or cords associated with accessories sold with the product may expose you to chemicals listed on proposition 65 known to the State of California and other governmental entities to cause cancer and birth defect or other reproductive harm.

**Wash hands after handling.**

D36-P5\_B1\_En

This product is for general household purposes. Any failure due to use for other than household purposes (such as long-term use for business purposes in a restaurant or use in a car or ship) and which requires repair will be charged for even during the warranty period.

K041\_A1\_En

(Symbol examples for batteries)

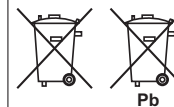

These symbols are only valid in the European Union.

K058c\_A1\_En

Thank you for buying this Pioneer product. Please read through these operating instructions so you will know how to operate your model properly. After you have finished reading the instructions, put them away in a safe place for future reference.

## Contents

<b>Before you start</b> .....	<b>5</b>
Checking what's in the box .....	5
Installing the receiver .....	5
<b>Flow of settings on the receiver</b> .....	<b>5</b>
<b>01 Controls and displays</b>	
Front panel .....	6
Display .....	7
Remote control .....	8
Loading the batteries .....	9
Operating range of remote control .....	9
<b>02 Connecting your equipment</b>	
Determining the speakers' application .....	10
Some tips for improving sound quality .....	10
Connecting the speakers .....	12
Switching the speaker terminal .....	12
Making cable connections .....	13
HDMI cables .....	13
About HDMI .....	13
Analog audio cables .....	13
Digital audio cables .....	13
Video cables .....	14
About the video converter .....	14
Connecting a TV and playback components .....	15
Connecting using HDMI .....	15
Connecting your TV with no HDMI input .....	16
Connecting your DVD player with no HDMI output .....	17
Connecting a satellite receiver or other digital set-top box .....	18
Connecting an HDD/DVD recorder, Blu-ray Disc recorder and other video sources .....	18
Using the component video jacks .....	19
Connecting other audio components .....	19
Connecting optional <i>Bluetooth</i> ® ADAPTER .....	20
Connecting your SiriusConnect™ Tuner .....	20
Connecting antennas .....	20
Using external antennas .....	21
Connecting to the front panel video terminal .....	21

Connecting an iPod .....	21
Connecting a USB device .....	22
Connecting an IR receiver .....	22
Switching components on and off using the 12 volt trigger .....	22
Plugging in the receiver .....	23
<b>03 Basic Setup</b>	
Automatically setting up for surround sound (MCACC) .....	24
Other problems when using the Auto MCACC setup .....	25
<b>04 Basic playback</b>	
Playing a source .....	26
Selecting the audio input signal .....	26
Playing an iPod .....	27
Playing back files stored on an iPod .....	28
Basic playback controls .....	28
Watching photos and video content .....	28
Playing a USB device .....	28
Basic playback controls .....	29
Compressed audio compatibility .....	29
<i>Bluetooth</i> ® ADAPTER for Wireless Enjoyment of Music .....	29
Wireless music play .....	29
Pairing the <i>Bluetooth</i> ADAPTER and <i>Bluetooth</i> wireless technology device .....	30
Listening to Music Contents of <i>Bluetooth</i> wireless technology device with Your System .....	30
Listening to Satellite Radio .....	30
Listening to SIRIUS Radio .....	31
Saving channel presets .....	31
Using the SIRIUS Menu .....	31
Listening to the radio .....	32
Improving FM sound .....	32
Saving station presets .....	32
Listening to station presets .....	32
Naming preset stations .....	32
<b>05 Listening to your system</b>	
Choosing the listening mode .....	33
Auto playback .....	33
Listening in surround sound .....	33
Using the Advanced surround .....	34
Using Stream Direct .....	34
Using the Sound Retriever .....	34
Listening with Acoustic Calibration EQ .....	34
Better sound using Phase Control .....	35
Using surround back channel processing .....	35
Setting the Up Mix function .....	35
Setting the Audio options .....	36
Making an audio or a video recording .....	37

<b>06 The System Setup menu</b>	
Using the System Setup menu .....	38
Manual speaker setup .....	38
Speaker Setting .....	38
Crossover Network .....	39
Channel Level .....	39
Speaker Distance .....	40
The Input Assign menu .....	40
The Speaker System setting .....	41
The Video Parameter setting .....	41
Video Converter .....	41
Resolution .....	41
Aspect .....	42
The Auto Power Down menu .....	42
The 12 V Trigger Setting .....	42
<b>07 Control with HDMI function</b>	
Making Control with HDMI connections .....	43
HDMI Setup .....	43
Before using synchronization .....	44
About synchronized operations .....	44
About connections with a product of a different brand that supports the Control with HDMI function .....	44
Cautions on the Control with HDMI function .....	44
<b>08 Using the MULTI-ZONE feature</b>	
MULTI-ZONE listening .....	45
Making MULTI-ZONE connections .....	45
Using the MULTI-ZONE controls .....	45
<b>09 Controlling the rest of your system</b>	
Setting the remote to control other components .....	46
Selecting preset codes directly .....	46
Clearing all the remote control settings .....	46
Controls for TVs .....	47
Controls for other components .....	47
Preset Code List .....	47
<b>10 Additional information</b>	
Troubleshooting .....	50
General .....	50
HDMI .....	51
Important information regarding the HDMI connection .....	51
iPod messages .....	52
USB messages .....	52
SIRIUS radio messages .....	52
About iPod/iPhone/iPad .....	52
Resetting the main unit .....	52
Cleaning the unit .....	53
Specifications .....	53



# Before you start

## Checking what's in the box

Please check that you've received the following supplied accessories:

- Setup microphone
- Remote control
- AAA size IEC R03 dry cell batteries (to confirm system operation) x2
- AM loop antenna
- FM wire antenna
- iPod cable
- These operating instructions

## Installing the receiver

- When installing this unit, make sure to put it on a level and stable surface.

Don't install it on the following places:

- on a color TV (the screen may distort)
- near a cassette deck (or close to a device that gives off a magnetic field). This may interfere with the sound.
- in direct sunlight
- in damp or wet areas
- in extremely hot or cold areas
- in places where there is vibration or other movement
- in places that are very dusty
- in places that have hot fumes or oils (such as a kitchen)

# Flow of settings on the receiver

The unit is a full-fledged AV receiver equipped with an abundance of functions and terminals. It can be used easily after following the procedure below to make the connections and settings.

*The colors of the steps indicate the following:*

### Required setting item

### Setting to be made as necessary

#### 1 Connecting the speakers

Where you place the speakers will have a big effect on the sound.

- Determining the speakers' application (page 10)
- Connecting the speakers (page 12)
- Switching the speaker terminal (page 12)



#### 2 Connecting the components

For surround sound, you'll want to hook up using a digital connection from the Blu-ray Disc/DVD player to the receiver.

- About the video converter (page 14)
- Connecting a TV and playback components (page 15)
- Connecting antennas (page 20)
- Plugging in the receiver (page 23)



#### 3 Power On

Make sure you've set the video input on your TV to this receiver. Check the manual that came with the TV if you don't know how to do this.



#### 4 The Speaker System setting (page 41)

*(Specify either using the surround back or front height speaker.)*

#### The Input Assign menu (page 40)

*(When using connections other than the recommended connections.)*

#### Using the Audio Return Channel function (page 43)

*(When the connected TV supports the HDMI Audio Return Channel function.)*



#### 5 Use the on-screen automatic MCACC setup to set up your system

- Automatically setting up for surround sound (MCACC) (page 24)



#### 6 Playing a source (page 26)

- Selecting the audio input signal (page 26)
- Playing an iPod (page 27)
- Playing a USB device (page 28)
- Choosing the listening mode (page 33)



#### 7 Adjusting the sound as desired

- Using the Sound Retriever (page 34)
- Better sound using Phase Control (page 35)
- Listening with Acoustic Calibration EQ (page 34)
- Using surround back channel processing (page 35)
- Setting the Up Mix function (page 35)
- Setting the Audio options (page 36)
- Manual speaker setup (page 38)



#### 8 Making maximum use of the remote control

- Setting the remote to control other components (page 46)

## Chapter 1:

## Controls and displays

## Front panel

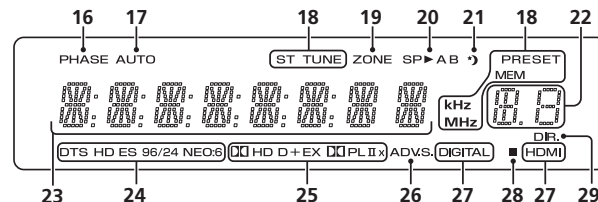
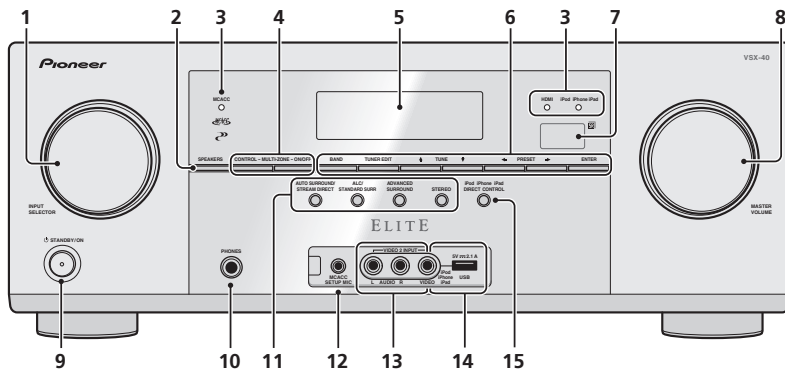
**1 INPUT SELECTOR dial**

Selects an input source (page 26).

**2 SPEAKERS button**

See *Switching the speaker terminal* on page 12.

**3 Indicators**

**MCACC** – Lights when Acoustic Calibration EQ (page 34) is on (Acoustic Calibration EQ is automatically set to on after the Auto MCACC setup (page 24)).

**HDMI** – Blinks when connecting an HDMI-equipped component; lights when the component is connected (page 15).

**iPod iPhone iPad** – Lights when an iPod/iPhone/iPad is connected and **iPod USB** input is selected (page 21).

**4 ZONE controls**

If you've made MULTI-ZONE connections (see *Making MULTI-ZONE connections* on page 45) use these controls to control the sub zone from the main zone (see *Using the MULTI-ZONE controls* on page 45).

**5 Character display**

See *Display* on page 7.

**6 Tuner control buttons**

**BAND** – Switches between AM, FM ST (stereo) and FM MONO radio bands (page 32).

**TUNER EDIT** – Use with **TUNE**  $\uparrow/\downarrow$ , **PRESET**  $\leftarrow/\rightarrow$  and **ENTER** to memorize and name stations for recall (page 32). Used to preset the channel in SIRIUS Radio (page 31).

**TUNE**  $\uparrow/\downarrow$  – Used to find radio frequencies (page 32) and SIRIUS Radio channels (page 31).

**PRESET**  $\leftarrow/\rightarrow$  – Use to select preset radio stations (page 32) and to select SIRIUS Radio channels (page 31).

**7 Remote sensor**

Receives the signals from the remote control (see *Operating range of remote control* on page 9).

**8 MASTER VOLUME dial****9  $\odot$  STANDBY/ON****10 PHONES jack**

Use to connect headphones. When the headphones are connected, there is no sound output from the speakers. The listening mode when the sound is heard from the headphone can be selected only from **PHONES SURR**, **STEREO** or **STEREO ALC** mode (**S.R AIR** mode can be also selected with **ADAPTER** input).

**11 Listening mode buttons**

**AUTO SURROUND/STREAM DIRECT** – Switches between Auto surround mode (page 33) and Stream Direct playback (page 34).

**ALC/STANDARD SURR** – Press for standard decoding and to switch between the modes of **II** Pro Logic II, **IIx** Pro Logic IIx, **IIz** Pro Logic IIz and NEO:6, and the Auto level control stereo mode (page 33).

**ADVANCED SURROUND** – Switches between the various surround modes (page 34).

**STEREO** – Press to select stereo playback (page 33).

**12 MCACC SETUP MIC jack**

Use to connect a microphone when performing Auto MCACC setup (page 24).

**13 AUDIO/VIDEO input terminal**

See *Connecting to the front panel video terminal* on page 21.

**14 iPod iPhone iPad/USB terminal**

Use to connect your Apple iPod or USB mass storage device as an audio source (page 21).

**15 iPod iPhone iPad DIRECT CONTROL**

Change the receiver's input to the **iPod** and enable iPod operations on the iPod (page 28).

**Display****16 PHASE**

Lights when the Phase Control is switched on (page 35).

**17 AUTO**

Lights when the Auto Surround feature is switched on (page 33).

**18 Tuner/SIRIUS indicators**

**ST** – Lights when a stereo FM broadcast is being received in auto stereo mode (page 32).

**TUNE** – Lights when a normal broadcast channel or SIRIUS channel is being received.

**PRESET** – Shows when a preset radio station is registered or called.

**MEM** – Blinks when a radio station is registered.

**kHz/MHz** – Lights when the character display is showing the currently received AM/FM broadcast frequency.

**19 Speaker indicators**

Indicates the speaker terminal, **A** and/or **B**, to which audio signal output is currently set (page 12).

**20 ZONE**

Lights when the MULTI-ZONE feature is active (page 45).

**21 Sleep timer indicator**

Lights when the receiver is in sleep mode (page 8).

**22 PRESET information or input signal indicator**

Shows the preset number of the tuner or the input signal type, etc.

**23 Character display**

Displays various system information.

**24 DTS indicators**

**DTS** – Lights when a source with DTS encoded audio signals is detected.

**HD** – Lights when a source with DTS-EXPRESS or DTS-HD encoded audio signals is detected.

**ES** – Lights to indicate DTS-ES decoding.

**96/24** – Lights when a source with DTS 96/24 encoded audio signals is detected.

**NEO:6** – When one of the NEO:6 modes of the receiver is on, this lights to indicate NEO:6 processing (page 33).

**25 Dolby Digital indicators**

**DD** – Lights when a Dolby Digital encoded signal is detected.

**DD+** – Lights when a source with Dolby Digital Plus encoded audio signals is detected.

**DDHD** – Lights when a source with Dolby TrueHD encoded audio signals is detected.

**EX** – Lights to indicate Dolby Digital EX decoding.

**DDPLI(x)** – Lights to indicate **II** Pro Logic II/**IIx** Pro Logic IIx decoding. Light will go off during **IIz** Pro Logic IIz decoding (see *Listening in surround sound* on page 33 for more on this).

**26 ADV.S.**

Lights when one of the Advanced Surround modes has been selected (see *Using the Advanced surround* on page 34 for more on this).

**27 SIGNAL SELECT indicators**

**DIGITAL** – Lights when a digital audio signal is selected. Blinks when a digital audio signal is selected and selected audio input is not provided.

**HDMI** – Lights when an HDMI signal is selected. Blinks when an HDMI signal is selected and selected HDMI input is not provided.

**28 Up Mix/DIMMER indicator**

Lights when the Up Mix function is set to **ON** (page 35). Also, lights when DIMMER is set to off.

**29 DIR.**

Lights when the **DIRECT** or **PURE DIRECT** mode is switched on (page 34).



- When the front speaker is set at **SMALL** in the Speaker Setting (or automatically via the Auto MCACC setup) and the Crossover Network is set above 150 Hz, the subwoofer channel level will be adjusted by pressing **BASS +/-** (page 39).

Press **TV** first to access:

**DTV/TV** – Switches between the DTV and analog TV input modes for Pioneer TVs.

### 10 Number buttons and other component controls

Use the number buttons to directly select a radio frequency (page 32) or the tracks on a CD, etc. There are other buttons that can be accessed after **[RECEIVER]** is pressed. (For example **MIDNIGHT**, etc.)

**HDD\***, **DVD\***, **VCR\*** – These buttons switch between the hard disk, DVD and VCR controls for HDD/DVD/VCR recorders.

**S.RETRIEVER** – Press to restore CD quality sound to compressed audio sources (page 34).

**SB CH** – Press to select **ON**, **AUTO** or **OFF** the surround back channel (page 35).

**CH SELECT** – Press repeatedly to select a channel, then use **LEV +/-** to adjust the level (page 39).

**LEV +/-** – Use to adjust the channel level.

**EQ** – Press to switch on/off Acoustic Calibration EQ setting (page 34).

**MIDNIGHT** – Switches to Midnight or Loudness listening (page 36).

**SPEAKERS** – See *Switching the speaker terminal* on page 12.

**PHASE** – Press to switch on/off Phase Control (page 35).

**DIMMER** – Dims or brightens the display. The brightness can be controlled in four steps.

**SIGNAL SEL** – Press to select the audio input signal of the component to play back (page 26).

Press **SIRIUS** first to access:

**D.ACCESS** – After pressing, you can access a radio station directly using the number buttons (page 31).

### 11 $\odot$ SOURCE

Press to turn on/off other components connected to the receiver (page 47).

### 12 TV CONTROL buttons

These buttons are dedicated to control the TV assigned to the **TV** button. Thus if you only have one TV to hook up to this system assign it to the **TV** button (page 47).

$\odot$  – Use to turn on/off the power of the TV.

**INPUT** – Use to select the TV input signal.

**CH +/-** – Use to select channels.

**VOL +/-** – Use to adjust the volume on your TV.

### 13 MASTER VOLUME +/-

Use to set the listening volume.

### 14 MUTE

Mutes/unmutes the sound.

### 15 DISP

Switches the display of this unit. The listening mode, sound volume, Speaker System setting or input name can be checked by selecting an input source.

- The Speaker Setting may or may not be displayed, depending on the input source you have selected.

### 16 SHIFT

Press to access the 'boxed' commands (above the buttons) on the remote. These buttons are marked with an asterisk (\*) in this section. This button is also used for operating ZONE 2 (page 45).

## Loading the batteries

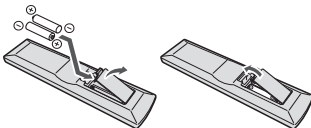

The batteries included with the unit are to check initial operations; they may not last over a long period. We recommend using alkaline batteries that have a longer life.

### **!** CAUTION

- Incorrect use of batteries may result in such hazards as leakage and bursting. Observe the following precautions:
  - Never use new and old batteries together.

- Insert the plus and minus sides of the batteries properly according to the marks in the battery case.
- Batteries with the same shape may have different voltages. Do not use different batteries together.
- When disposing of used batteries, please comply with governmental regulations or environmental public instruction's rules that apply in your country or area.
- Do not use or store batteries in direct sunlight or other excessively hot place, such as inside a car or near a heater. This can cause batteries to leak, overheat, explode or catch fire. It can also reduce the life or performance of batteries.

## Operating range of remote control

The remote control may not work properly if:

- There are obstacles between the remote control and the receiver's remote sensor.
- Direct sunlight or fluorescent light is shining onto the remote sensor.
- The receiver is located near a device that is emitting infrared rays.
- The receiver is operated simultaneously with another infrared remote control unit.

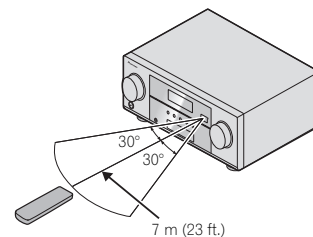

## Chapter 2: Connecting your equipment

### Determining the speakers' application

By connecting the left and right front speakers (L/R), the center speaker (C), the left and right surround speakers (SL/SR), the left and right surround back speakers (SBL/SBR) (or the left and right front height speakers (FHL/FHR)), and the subwoofer (SW), a surround sound system up to 7.1 channel can be enjoyed.

The 5.1 channel surround system is the most commonly used in home theaters. To achieve the best possible surround sound, install your speakers as shown below.

5.1 channel surround system:

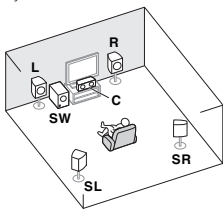

6.1 channel surround (Surround back) system:

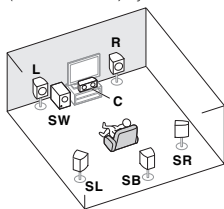

7.1 channel surround (Surround back) system:

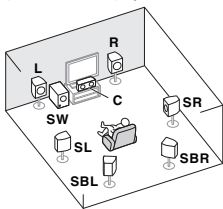

7.1 channel surround (Front height) system:

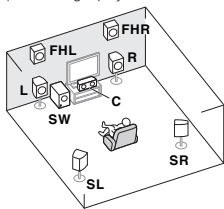

### Note

- Both the surround back speakers and the front height speakers can be connected at the same time. In this case, sound will be output from either the front height speaker or the surround back speaker depending on which one was selected in the **Speaker System** setting (see *The Speaker System setting* on page 41).

### Speaker B connection

You can use the speakers connected to the B speaker terminals to listen to stereo playback in another room. See *Switching the speaker terminal* on page 12 for the listening options with this setup.

- You will not be able to connect the B speakers if you connect the front height speakers in the main zone.** Further, if you use the B speakers, a 5.1 ch playback will be the maximum in the main zone. (No sound is output from the surround back speaker.)

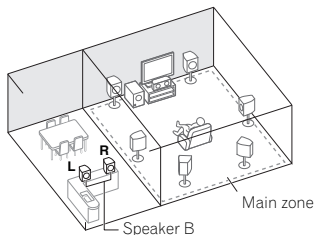

### Important

- The Speaker System setting must be set if the above connections are performed. Select **Surr.Back** if the surround back speaker or speaker B is connected, and **Height** if the front height speaker is connected (see *The Speaker System setting* on page 41).

### ZONE 2 connection (Multi Zone)

With these connections you can simultaneously enjoy the surround sound in the main zone with stereo playback on another component in ZONE 2 (The selection of input devices is limited). See *MULTI-ZONE listening* on page 45.

- To connect the ZONE 2 speakers, an additional amplifier is required.

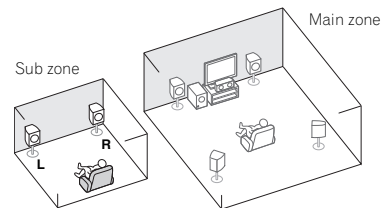

### Some tips for improving sound quality

Where you put your speakers in the room has a big effect on the quality of the sound. The following guidelines should help you to get the best sound from your system.

- It is best to angle the speakers towards the listening position. The angle depends on the size of the room. Use less of an angle for bigger rooms.
- Refer to the chart below for placement of speakers you intend to connect.

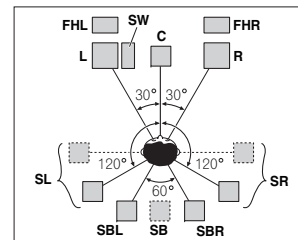

- Place the surround speakers at 120° from the center. If you, (1) use the surround back speaker, and, (2) don't use the front height speakers, we recommend placing the surround speaker right beside you.
- If you intend to connect only one surround back speakers, place it directly behind you.

- If the surround speakers cannot be set directly to the side of the listening position with a 7.1-channel system, the surround effect can be enhanced by turning off the Up Mix function (see *Setting the Up Mix function* on page 35).
- For the best stereo effect, place the front speakers 2 m to 3 m (6 ft. to 9 ft.) apart, at equal distance from the TV.
- If you're using a center speaker, place the front speakers at a wider angle. If not, place them at a narrower angle.
- Place the center speaker above or below the TV so that the sound of the center channel is localized at the TV screen. Also, make sure the center speaker does not cross the line formed by the leading edge of the front left and right speakers.
- Surround and surround back speakers should be positioned 60 cm to 90 cm (2 ft. to 3 ft.) higher than your ears and tilted slight downward. Make sure the speakers don't face each other. For DVD-Audio, the speakers should be more directly behind the listener than for home theater playback.
- Try not to place the surround speakers farther away from the listening position than the front and center speakers. Doing so can weaken the surround sound effect.
- Place the left and right front height speakers at least one meter (3.3 ft.) directly above the left and right front speakers.
- If you're going to place speakers around your CRT TV, use shielded speakers or place the speakers at a sufficient distance from your CRT TV.
- The subwoofer can be placed on the floor. Ideally, the other speakers should be at about ear-level when you're listening to them. Putting the speakers on the floor (except the subwoofer), or mounting them very high on a wall is not recommended.
- When not connecting a subwoofer, connect speakers with low frequency reproduction capabilities to the front channel. (The subwoofer's low frequency component is played from the front speakers, so the speakers could be damaged.)
- **After connecting, be sure to conduct the Auto MCACC (speaker environment setting) procedure.** See *Automatically setting up for surround sound (MCACC)* on page 24.

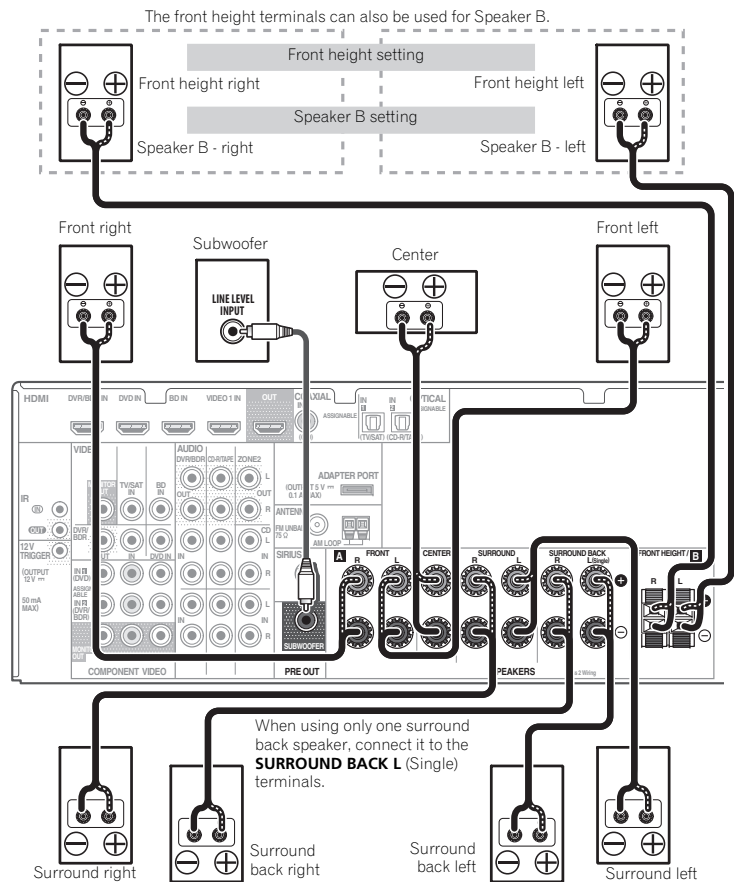

**⚠ CAUTION**

- Make sure that all speakers are securely installed. This not only improves sound quality, but also reduces the risk of damage or injury resulting from speakers being knocked over or falling in the event of external shocks such as earthquakes.

**Connecting the speakers**

The receiver will work with just two stereo speakers (the front speakers in the diagram) but using at least three speakers is recommended, and a complete setup is best for surround sound.

Make sure you connect the speaker on the right to the right (**R**) terminal and the speaker on the left to the left (**L**) terminal. Also make sure the positive and negative (+/-) terminals on the receiver match those on the speakers.

You can use speakers with a normal impedance between 6  $\Omega$  and 16  $\Omega$ .

*Be sure to complete all connections before connecting this unit to the AC power source.*

**Bare wire connections**

*A-Speaker terminals:*

- 1 **Twist exposed wire strands together.**
- 2 **Loosen terminal and insert exposed wire.**
- 3 **Tighten terminal.**

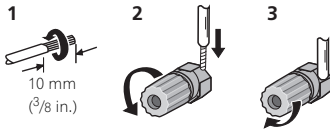

*B-Speaker terminals:*

- 1 **Twist exposed wire strands together.**
- 2 **Push open the tabs and insert exposed wire.**
- 3 **Release the tabs.**

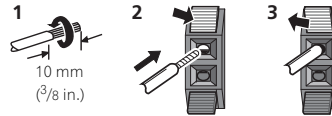
**⚠ CAUTION**

- These speaker terminals carry **HAZARDOUS LIVE voltage**. To prevent the risk of electric shock when connecting or disconnecting the speaker cables, disconnect the power cord before touching any uninsulated parts.
- Make sure that all the bare speaker wire is twisted together and inserted fully into the speaker terminal. If any of the bare speaker wire touches the back panel it may cause the power to cut off as a safety measure.

**Switching the speaker terminal**

If you selected **Surr.Back** in *The Speaker System setting* on page 41, you can switch between speakers using the **SPEAKERS** button. If you selected **Height**, the button will simply switch your main speaker terminal on or off. The options below are for the **Surr.Back** setting only.

- Use the **SPEAKERS** button on the front panel to select a speaker terminal setting.



Press repeatedly to choose a speaker terminal option:

- **SP▶A** – Sound is output from the speakers connected to the A-speaker terminals (multichannel playback is possible).
- **SP▶B** – Sound is output from the two speakers connected to the B-speaker terminals (only stereo playback is possible).
- **SP▶AB** – Sound is output from the A-speaker terminals, the two speakers in the B-speaker terminals, and the subwoofer. Multichannel sources are downmixed only when the **STEREO** or **STEREO ALC** mode is selected for stereo output from A- and B-speaker terminals.
- **SP▶** – No sound is output from the speakers.

**🔧 Note**

- The subwoofer output depends on the settings you made in *Speaker Setting* on page 38. However, if **SP▶B** is selected above, no sound is heard from the subwoofer (the LFE channel is not downmixed).
- All speaker terminals are switched off when headphones are connected.



## Making cable connections

Make sure not to bend the cables over the top of this unit (as shown in the illustration). If this happens, the magnetic field produced by the transformers in this unit may cause a humming noise from the speakers.

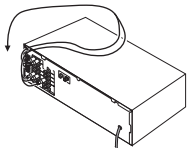

### Important

- Before making or changing connections, switch off the power and disconnect the power cord from the AC outlet.
- Before unplugging the power cord, switch the power into standby.

## HDMI cables

Both video and sound signals can be transmitted simultaneously with one cable. If connecting the player and the TV via this receiver, for both connections, we recommend using HDMI cables.

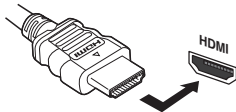

Be careful to connect the terminal in the proper direction.

### Note

- Set the HDMI parameter in *Setting the Audio options* on page 36 to **THRU** (THROUGH) and set the input signal in *Selecting the audio input signal* on page 26 to **HDMI**, if you want to hear HDMI audio output from your TV (no sound will be heard from this receiver).

- If the video signal does not appear on your TV, try adjusting the resolution settings on your component or display. Note that some components (such as video game units) have resolutions that may not be displayed. In this case, use a (analog) composite connection.
- When the video signal from the HDMI is 480i, 480p, 576i or 576p, Multi Ch PCM sound and HD sound cannot be received.

## About HDMI

The HDMI connection transfers uncompressed digital video, as well as almost every kind of digital audio that the connected component is compatible with, including DVD-Video, DVD-Audio, SACD, Dolby Digital Plus, Dolby TrueHD, DTS-HD Master Audio (see below for limitations), Video CD/ Super VCD and CD.

This receiver incorporates High-Definition Multimedia Interface (HDMI<sup>®</sup>) technology.

This receiver supports the functions described below through HDMI connections.

- Digital transfer of uncompressed video (contents protected by HDCP (1080p/24, 1080p/60, etc.))
- 3D signal transfer
- Deep Color signal transfer
- x.v.Color signal transfer
- Audio Return Channel
- Input of multi-channel linear PCM digital audio signals (192 kHz or less) for up to 8 channels
- Input of the following digital audio formats:
  - Dolby Digital, Dolby Digital Plus, DTS, High bitrate audio (Dolby TrueHD, DTS-HD Master Audio), DVD-Audio, CD, SACD (DSD 2 ch only), Video CD, Super VCD
- Synchronized operation with components using the **Control** with HDMI function (see *Control with HDMI function* on page 43)

### Note

- Use a High Speed HDMI<sup>®</sup> cable. If HDMI cable other than a High Speed HDMI<sup>®</sup> cable is used, it may not work properly.
- When an HDMI cable with a built-in equalizer is connected, it may not operate properly.

- 3D, Deep Color, x.v.Color signal transfer and Audio Return Channel are only possible when connected to a compatible component.
- HDMI format digital audio transmissions require a longer time to be recognized. Due to this, interruption in the audio may occur when switching between audio formats or beginning playback.
- Turning on/off the device connected to this unit's HDMI OUT terminal during playback, or disconnecting/ connecting the HDMI cable during playback, may cause noise or interrupted audio.

*HDMI, the HDMI Logo and High-Definition Multimedia Interface are trademarks or registered trademarks of HDMI Licensing, LLC in the United States and other countries.*

*"x.v.Color" and x.v.Color are trademarks of Sony Corporation.*

## Analog audio cables

Use stereo RCA phono cables to connect analog audio components. These cables are typically red and white, and you should connect the red plugs to R (right) terminals and white plugs to L (left) terminals.

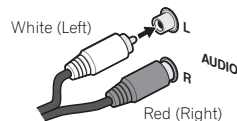

## Digital audio cables

Commercially available coaxial digital audio cables or optical cables should be used to connect digital components to this receiver.

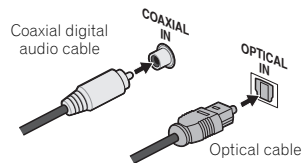

**Note**

- When connecting optical cables, be careful when inserting the plug not to damage the shutter protecting the optical socket.
- When storing optical cable, coil loosely. The cable may be damaged if bent around sharp corners.
- You can also use a standard RCA video cable for coaxial digital connections.

**Video cables****Standard RCA video cables**

These cables are the most common type of video connection and are used to connect to the composite video terminals. The yellow plugs distinguish them from cables for audio.

**Component video cables**

Use component video cables to get the best possible color reproduction of your video source. The color signal of the TV is divided into the luminance (Y) signal and the color (Pb and Pr) signals and then output. In this way, interference between the signals is avoided.

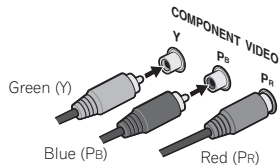
**About the video converter**

The video converter ensures that all video sources are output from **HDMI OUT** terminal. The only exception is HDMI: since this resolution cannot be downsampled, you must connect your monitor/TV to the receiver's HDMI video outputs when connecting this video source.

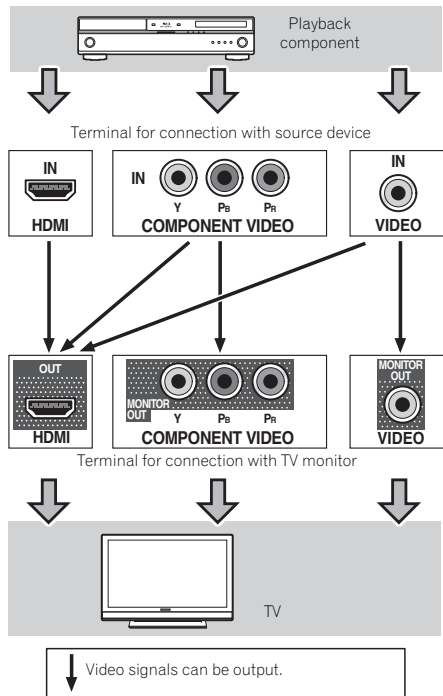
**Note**

- If several video components are assigned to the same input function, the converter gives priority to HDMI, component, then composite (in that order).
- If the video signal does not appear on your TV, try adjusting the resolution settings on your component or display. Note that some components (such as video game units) have resolutions that may not be converted. In this case, try switching Video Converter **OFF** (see *Video Converter* on page 41).
- The signal input resolutions that can be converted from the component video input for the HDMI output are 480i/576i, 480p/576p, 720p and 1080i. 1080p signal cannot be converted.

*This item incorporates copy protection technology that is protected by U.S. patents and other intellectual property rights of Rovi Corporation. Reverse engineering and disassembly are prohibited.*

## Connecting a TV and playback components

### Connecting using HDMI

If you have an HDMI or DVI (with HDCP) equipped component (Blu-ray Disc player, etc.), you can connect it to this receiver using a commercially available HDMI cable.

If the TV and playback components support the **Control** with HDMI feature, the convenient **Control** with HDMI functions can be used (see *Control with HDMI function* on page 43).

- The following connection/setting is required to listen to the sound of the TV over this receiver.
  - If the TV does not support the HDMI Audio Return Channel function, connect the receiver and TV with audio cables (as shown).
  - If the TV supports the HDMI Audio Return Channel function, the sound of the TV is input to the receiver via the HDMI terminal, so there is no need to connect an audio cable. In this case, set **ARC** at **HDMI Setup** to **ON** (see *HDMI Setup* on page 43).

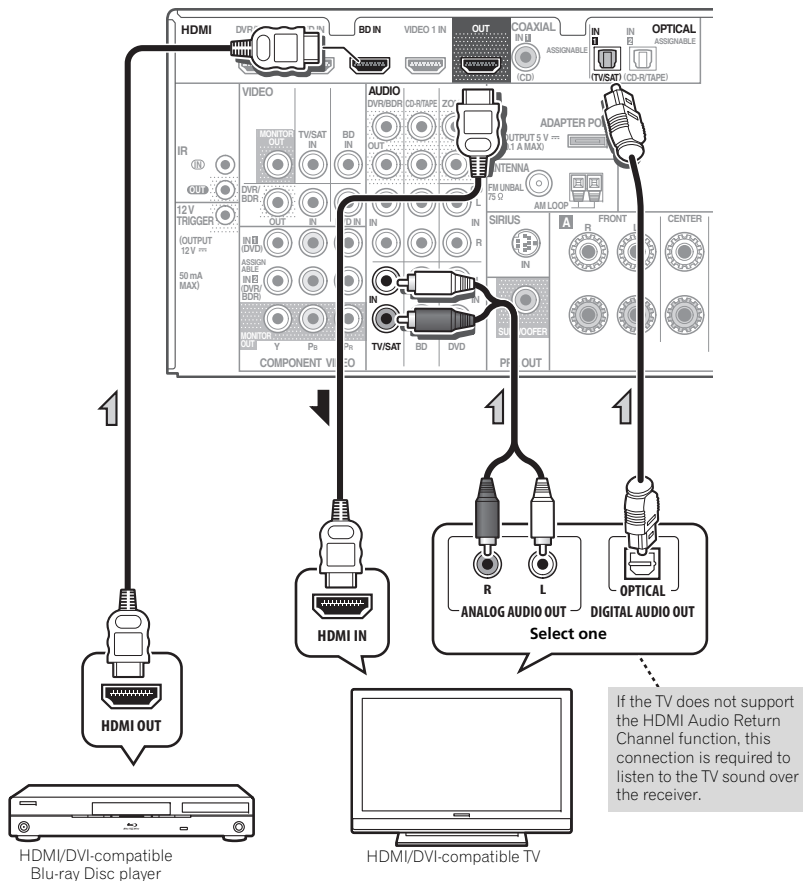

### Connecting your TV with no HDMI input

This diagram shows connections of a TV (with no HDMI input) and DVD player (or other playback component) to the receiver.

- With these connections, the picture is not output to the TV even if the DVD player is connected with an HDMI cable. Connect the DVD player's video signals using a composite or component cable.
- Connect using an HDMI cable to listen to HD audio on the receiver. Do not use an HDMI cable to input video signals. Depending on the video component, it may not be possible to output signals connected by HDMI and other methods simultaneously, and it may be necessary to make output settings. Please refer to the operating instructions supplied with your component for more information.
- If both TV and player has a component video jacks, you can connect these too. See *Using the component video jacks* on page 19 for more on this.

#### Note

- In order to listen to the audio from the DVD player that is connected to this receiver using an optical cable or a coaxial cable, first, switch to the **DVD** input, then use **RECEIVER** and **SIGNAL SEL** to choose the audio signal **O2** (OPTICAL2) or **C1** (COAXIAL1) (see *Selecting the audio input signal* on page 26).

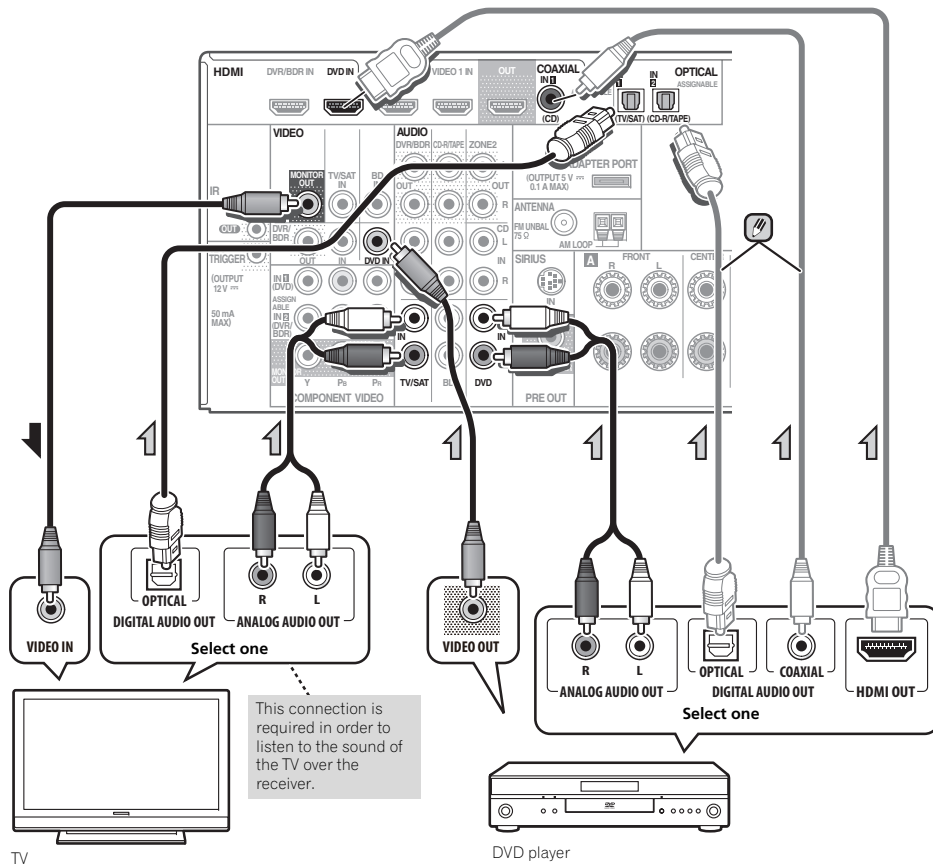

## Connecting your DVD player with no HDMI output

This diagram shows connections of a TV (with HDMI input) and DVD player (or other playback component with no HDMI output) to the receiver.

- If your player has a component video output, you can connect these too. See *Using the component video jacks* on page 19 for more on this.
- The following connection/setting is required to listen to the sound of the TV over this receiver.
  - If the TV does not support the HDMI Audio Return Channel function, connect the receiver and TV with audio cables (as shown).
  - If the TV supports the HDMI Audio Return Channel function, the sound of the TV is input to the receiver via the HDMI terminal, so there is no need to connect an audio cable. In this case, set **ARC** at **HDMI Setup** to **ON** (see *HDMI Setup* on page 43).

### Note

- In order to listen to the audio from the DVD player that is connected to this receiver using an optical cable or a coaxial cable, first, switch to the **DVD** input, then use **RECEIVER** and **SIGNAL SEL** to choose the audio signal **O2** (OPTICAL2) or **C1** (COAXIAL1) (see *Selecting the audio input signal* on page 26).

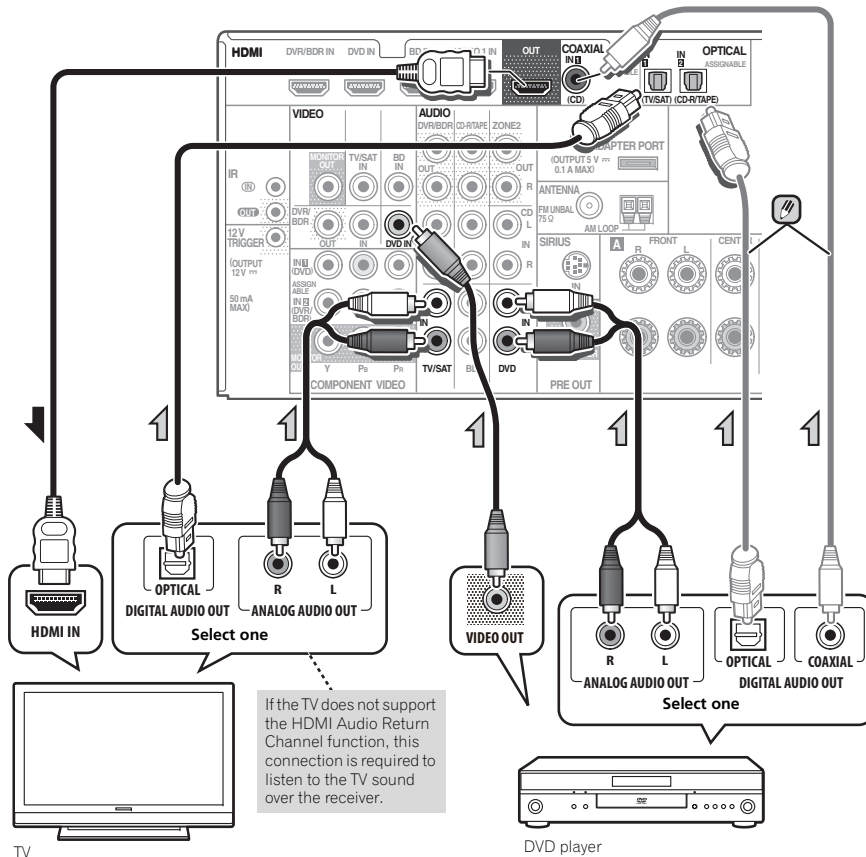

### Connecting a satellite receiver or other digital set-top box

Satellite and cable receivers, and terrestrial digital TV tuners are all examples of so-called 'set-top boxes'.

- If the set-top box or video component also has an HDMI or a component video output, you can connect this too. See *Connecting using HDMI* on page 15 or *Using the component video jacks* on page 19 for more on this.

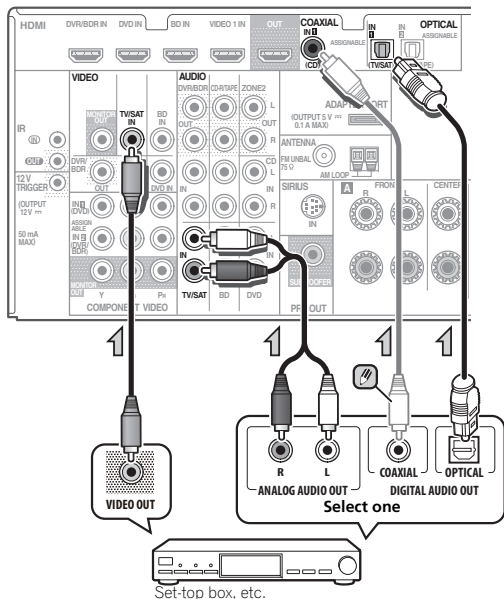

#### Note

- In order to listen to the audio from the source component that is connected to this receiver using a coaxial cable, first, switch to the **TV/SAT**, then use **RECEIVER** and **SIGNAL SEL** to choose the audio signal **C1** (COAXIAL1) (see *Selecting the audio input signal* on page 26).

### Connecting an HDD/DVD recorder, Blu-ray Disc recorder and other video sources

This receiver has audio/video inputs and outputs suitable for connecting analog or digital video recorders, including HDD/DVD recorders and Blu-ray Disc recorders.

- Only the signals that are input to the VIDEO IN terminal can be output from the VIDEO OUT terminal.
- Audio signals that are input through the digital terminal will not be output from the analog terminal.

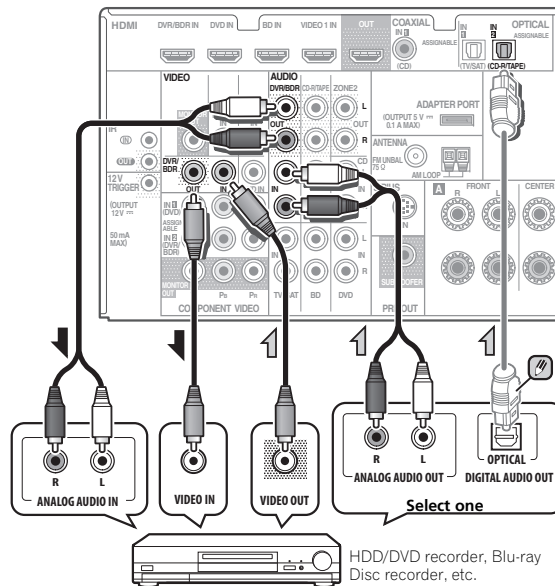

#### Note

- In order to listen to the audio from the source component that is connected to this receiver using an optical cable, first, switch to the **DVR/BDR** input, then use **RECEIVER** and **SIGNAL SEL** to choose the audio signal **O2** (OPTICAL2) (see *Selecting the audio input signal* on page 26).

## Using the component video jacks

Component video should deliver superior picture quality when compared to composite video. A further advantage (if your source and TV are both compatible) is progressive-scan video, which delivers a very stable, flicker-free picture. See the manuals that came with your TV and source component to check whether they are compatible with progressive-scan video.

- For the audio connection, refer to *Connecting your DVD player with no HDMI input* on page 17.

### Important

- If you connect any source component to the receiver using a component video input, you must also have your TV connected to this receiver's **COMPONENT VIDEO MONITOR OUT** jacks.
- If necessary, assign the component video inputs to the input source you've connected. This only needs to be done if you didn't connect according to the following defaults:

- **COMPONENT VIDEO IN 1: DVD**

- **COMPONENT VIDEO IN 2: DVR/BDR**

See *The Input Assign menu* on page 40 for more on this.

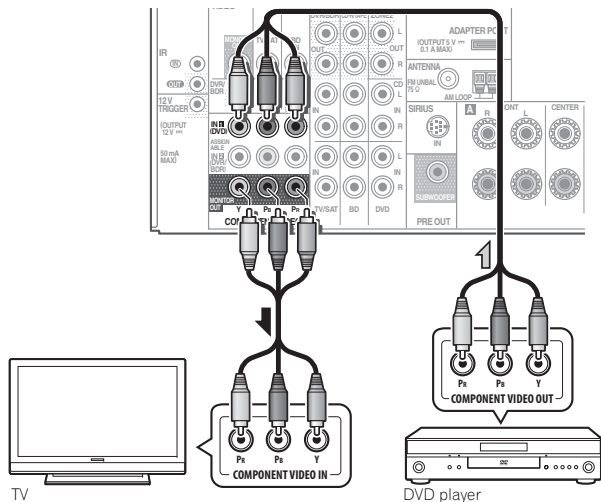

## Connecting other audio components

The number and kind of connections depends on the kind of component you're connecting. Follow the steps below to connect a CD-R, MD, DAT, tape recorder or other audio component.

- Note that you must connect digital components to analog audio jacks if you want to record to/from digital components (like an MD) to/from analog components.

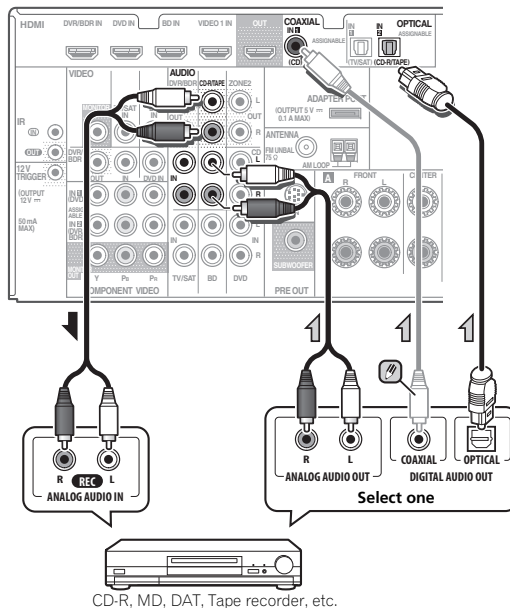

CD-R, MD, DAT, Tape recorder, etc.

### Note

- In order to listen to the audio from the CD player that is connected to this receiver using a coaxial cable, first, switch to the **CD-R** input, then use **RECEIVER** and **SIGNAL SEL** to choose the audio signal **C1** (COAXIAL1) (see *Selecting the audio input signal* on page 26).

### Connecting optional Bluetooth® ADAPTER

When the *Bluetooth* ADAPTER (Pioneer Model No. AS-BT100 or AS-BT200) is connected to this unit, a product equipped with *Bluetooth* wireless technology (portable cell phone, digital music player, etc.) can be used to listen to music wirelessly.

- Connect a *Bluetooth* ADAPTER to the ADAPTER PORT terminal on the rear panel.

- For instructions on playing the *Bluetooth* wireless technology device, see *Pairing the Bluetooth ADAPTER and Bluetooth wireless technology device* on page 30.

#### Important

- Do not move the receiver with the *Bluetooth* ADAPTER connected. Doing so could cause damage or faulty contact.

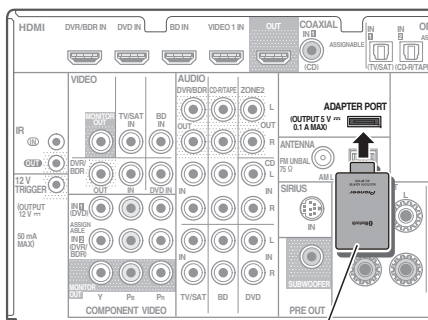

Bluetooth® ADAPTER

### Connecting your SiriusConnect™ Tuner

To receive SIRIUS Satellite Radio broadcasts, you will need to activate your SiriusConnect tuner.

- Connect a SiriusConnect tuner to the SIRIUS IN jack on the rear panel.

- You will also need to connect the antenna and AC adapter to the SiriusConnect tuner.
- For instructions on playing the SIRIUS Radio, see *Listening to SIRIUS Radio* on page 31.

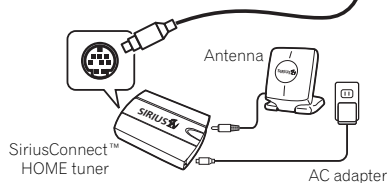
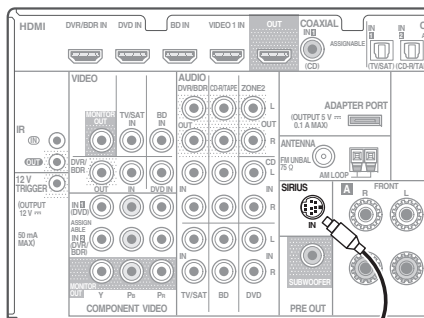

### Connecting antennas

Connect the AM loop antenna and the FM wire antenna as shown below. To improve reception and sound quality, connect external antennas (see *Using external antennas* below).

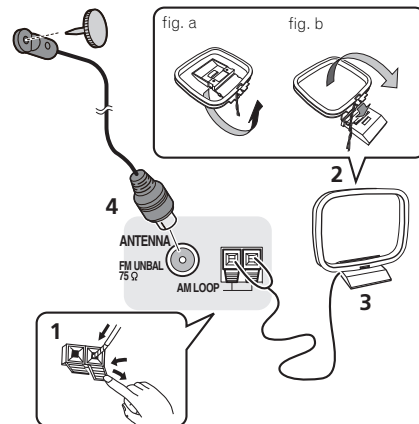

**1** Push open the tabs, then insert one wire fully into each terminal, then release the tabs to secure the AM antenna wires.

**2** Fix the AM loop antenna to the attached stand.

To fix the stand to the antenna, bend in the direction indicated by the arrow (fig. a) then clip the loop onto the stand (fig. b).

**3** Place the AM antenna on a flat surface and in a direction giving the best reception.

**4** Connect the FM wire antenna into the FM antenna socket.

For best results, extend the FM antenna fully and fix to a wall or door frame. Don't drape loosely or leave coiled up.



## Using external antennas

### To improve FM reception

Use an F connector (not supplied) to connect an external FM antenna.

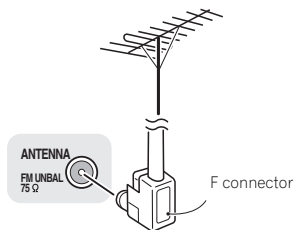

### To improve AM reception

Connect a 5 m to 6 m (16 ft. to 20 ft.) length of vinyl-coated wire to the AM antenna terminal without disconnecting the supplied AM loop antenna.

For the best possible reception, suspend horizontally outdoors.

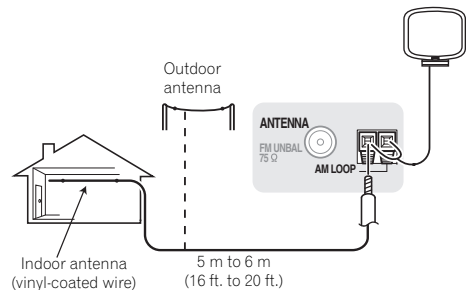

## Connecting to the front panel video terminal

Front video connections are accessed via the front panel using the **INPUT SELECTOR** or **VIDEO2** button on the remote control. There are standard audio/video jacks. Hook them up the same way you made the rear panel connections.

- Push down on the **PUSH OPEN** tab to access the front video connections.

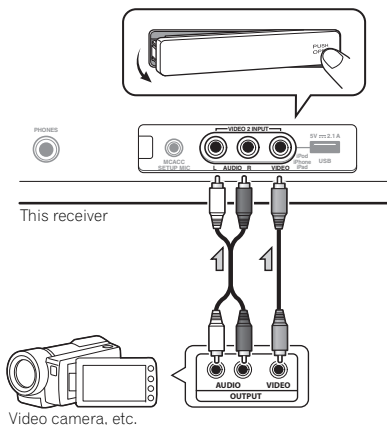

## Connecting an iPod

This receiver has a dedicated iPod terminal that will allow you to control playback of audio content from your iPod using the controls of this receiver.

- **Switch the receiver into standby, and then use the iPod cable to connect your iPod to the iPod terminal on the front panel of this receiver.**

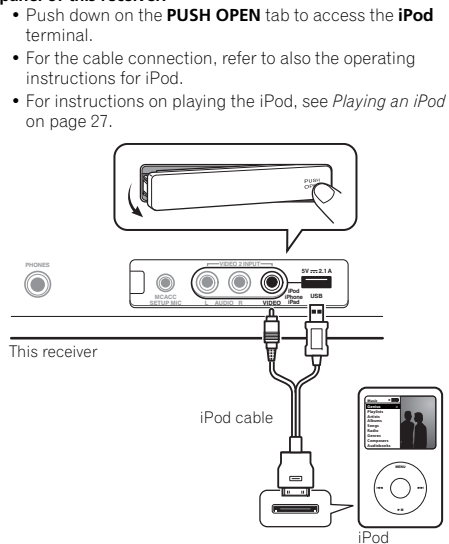

### Connecting a USB device

It is possible to listen to two-channel audio using the USB interface on the front of this receiver.

- **Switch the receiver into standby then connect your USB device to the USB terminal on the front panel of this receiver.**

- Push down on the **PUSH OPEN** tab to access the **USB** terminal.
- This receiver does not support a USB hub.
- For instructions on playing the USB device, see *Playing a USB device* on page 28.

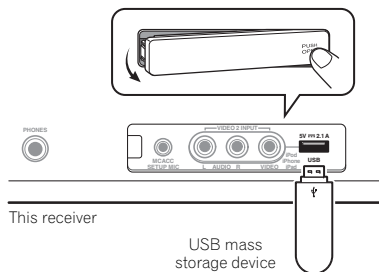

### Connecting an IR receiver

If you keep your stereo components in a closed cabinet or shelving unit, or you wish to use the sub zone remote control in another zone, you can use an optional IR receiver (such as a Niles or Xantech unit) to control your system instead of the remote sensor on the front panel of this receiver.

#### Note

- Remote operation may not be possible if direct light from a strong fluorescent lamp is shining on the IR receiver remote sensor window.
- Note that other manufacturers may not use the IR terminology. Refer to the manual that came with your component to check for IR compatibility.

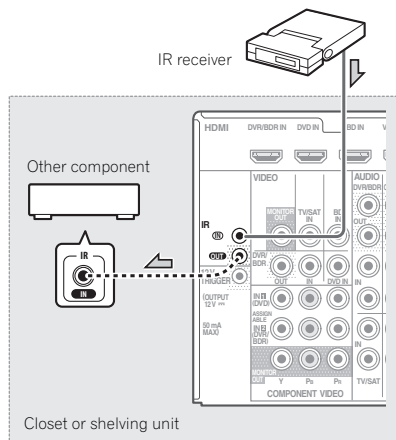

- **Connect the IR receiver sensor to the IR IN jack on the rear of this receiver.**

For more information on connecting the IR receiver, see the Installation Instructions for the IR Receiver.

### Switching components on and off using the 12 volt trigger

You can connect components in your system (such as a screen or projector) to this receiver so that they switch on or off using 12 volt triggers when you select an input function. However, you must specify which input functions switch on the trigger using the *The 12 V Trigger Setting* on page 42. Note that this will only work with components that have a standby mode.

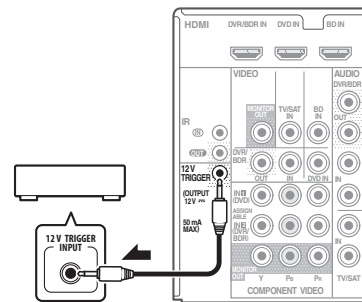

- **Connect the 12 V TRIGGER jack of this receiver to the 12 V trigger of another component.**

Use a cable with a mono mini-plug on each end for the connection.

After you've specified the input functions that will switch on the trigger, you'll be able to switch the component on or off just by pressing the input function(s) you've set on page 42.

---

### Plugging in the receiver

Only plug in after you have connected all your components to this receiver, including the speakers.

- **Plug the AC power cord into a convenient AC power outlet.**

#### CAUTION

- Handle the power cord by the plug part. Do not pull out the plug by tugging the cord, and never touch the power cord when your hands are wet, as this could cause a short circuit or electric shock. Do not place the unit, a piece of furniture, or other object on the power cord or pinch the cord in any other way. Never make a knot in the cord or tie it with other cables. The power cords should be routed so that they are not likely to be stepped on. A damaged power cord can cause a fire or give you an electric shock. Check the power cord once in a while. If you find it damaged, ask your nearest Pioneer authorized independent service company for a replacement.
- The receiver should be disconnected by removing the mains plug from the wall socket when not in regular use, e.g., when on vacation.

#### Note

- After this receiver is connected to an AC outlet, a 2 second to 10 second HDMI initialization process begins. You cannot carry out any operations during this process. The **HDMI** indicator in the front panel display blinks during this process, and you can turn on this receiver once it has stopped blinking. When you set the **Control** with HDMI to **OFF**, you can skip this process. For details about the **Control** with HDMI feature, see *Control with HDMI function* on page 43.

## Chapter 3: Basic Setup

### Automatically setting up for surround sound (MCACC)

The Auto Multi-Channel Acoustic Calibration (MCACC) setup measures the acoustic characteristics of your listening area, taking into account ambient noise, speaker size and distance, and tests for both channel delay and channel level. After you have set up the microphone provided with your system, the receiver uses the information from a series of test tones to optimize the speaker settings and equalization for your particular room.

#### ⚠ CAUTION

- The test tones used in the Auto MCACC setup are output at high volume.

#### 📌 Important

- The Auto MCACC setup will overwrite any existing speaker settings you've made.
- Before using the Auto MCACC setup, the **iPod USB** input should not be selected as an input source.
- When both the surround back speaker and the front height speaker are connected, conduct Auto MCACC setup twice: once with the Speaker System setting is in **Surr.Back** and once with the Speaker System setting is in **Height**. (There is no need to conduct Auto MCACC setup every time the Speaker System setting is changed.)

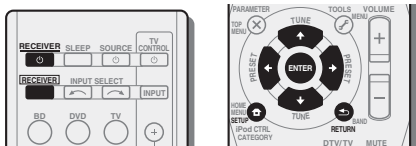

- 1 Switch on the receiver and your TV.
- 2 Switch the TV input so that it connects to the receiver.
- 3 Connect the microphone to the MCACC SETUP MIC jack on the front panel.

Make sure there are no obstacles between the speakers and the microphone.

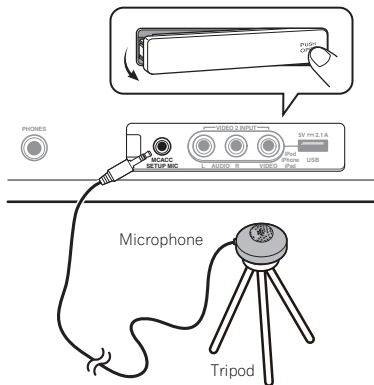

If you have a tripod, use it to place the microphone so that it's about ear level at your normal listening position. Otherwise, place the microphone at ear level using a table or a chair.

- 4 Press **RECEIVER** on the remote control, then press the **SETUP** button.

The System Setup menu appears on your TV. Use **↑/↓/←/→** and **ENTER** on the remote control to navigate through the screens and select menu items. Press **RETURN** to exit the current menu.

- Press **SETUP** at any time to exit the System Setup menu. If you cancel the Auto MCACC setup at any time, the receiver automatically exits and no settings will be made.
- The screensaver automatically starts after three minutes of inactivity.

- 5 Select 'Auto MCACC' from the System Setup menu, then press **ENTER**.

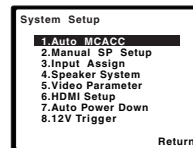

- **MIC IN** blinks when the microphone is not connected to MCACC SETUP MIC jack.

Try to be as quiet as possible after pressing **ENTER**. The system outputs a series of test tones to establish the ambient noise level.

- 6 Follow the instructions on-screen.

- Make sure the microphone is connected.
- Make sure the subwoofer is on and the volume is turned up.
- When using surround back or front height speakers, turn on the power to the amplifier to which the surround back or front height speakers are connected, and adjust the sound level to the desired level.
- See below for notes regarding background noise and other possible interference.

- 7 Wait for the test tones to finish.

A progress report is displayed on-screen while the receiver outputs test tones to determine the speakers present in your setup. Try to be as quiet as possible while it's doing this.

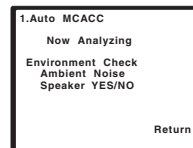

- For correct speaker settings, do not adjust the volume during the test tones.

### 8 Confirm the speaker configuration.

The configuration shown on-screen should reflect the actual speakers you have.

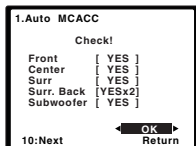

- With error messages (such as **Too much ambient noise**) select **RETRY** after checking for ambient noise (see *Other problems when using the Auto MCACC setup* below).

If the speaker configuration displayed isn't correct, use **↑/↓** to select the speaker and **←/→** to change the setting. When you're finished, go to the next step.

If you see an error message (**ERR**) in the right side column, there may be a problem with the speaker connection. If selecting **RETRY** doesn't fix the problem, turn off the power and check the speaker connections.

### 9 Make sure 'OK' is selected, then press ENTER.

If the screen in step 7 is left untouched for 10 seconds and **ENTER** is not pressed in step 8, the Auto MCACC setup will start automatically as shown.

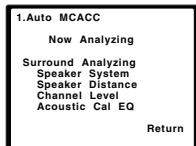

A progress report is displayed on-screen while the receiver outputs more test tones to determine the optimum receiver settings for channel level, speaker distance, and Acoustic Calibration EQ.

Again, try to be as quiet as possible while this is happening. It may take 1 to 3 minutes.

### 10 The Auto MCACC setup has finished! You return to the System Setup menu.

The settings made in the Auto MCACC setup should give you excellent surround sound from your system, but it is also possible to adjust these settings manually using the System Setup menu (starting on page 38).

#### Note

- Depending on the characteristics of your room, sometimes identical speakers with cone sizes of around 12 cm (5 inches) will end up with different size settings. You can correct the setting manually using the *Speaker Setting* on page 38.
- The subwoofer distance setting may be farther than the actual distance from the listening position. This setting should be accurate (taking delay and room characteristics into account) and generally does not need to be changed.

### Other problems when using the Auto MCACC setup

If the room environment is not optimal for the Auto MCACC setup (too much background noise, echo off the walls, obstacles blocking the speakers from the microphone) the final settings may be incorrect. Check for household appliances (air conditioner, fridge, fan, etc.), that may be affecting the environment and switch them off if necessary. If there are any instructions showing in the front panel display, please follow them.

- Some older TVs may interfere with the operation of the microphone. If this seems to be happening, switch off the TV when doing the Auto MCACC setup.

## Chapter 4: Basic playback

### Playing a source

Here are the basic instructions for playing a source (such as a DVD disc) with your home theater system.

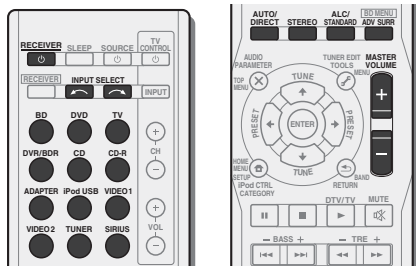

#### 1 Switch on your system components and receiver.

Start by switching on the playback component (for example a DVD player), your TV and subwoofer (if you have one), then the receiver (press **RECEIVER**).

- Make sure the setup microphone is disconnected.

#### 2 Switch the TV input to the input that connects this receiver.

For example, if you connected this receiver to the **VIDEO** jacks on your TV, make sure that the **VIDEO** input is now selected.

#### 3 Press input function buttons to select the input function you want to play.

- The input of the receiver will switch over, and you will be able to operate other components using the remote control. To operate the receiver, first press **RECEIVER** on the remote control, then press the appropriate button to operate.
- The input source can also be selected by using **INPUT SELECT** buttons on the remote control, or by using the front panel **INPUT SELECTOR** dial. In this case, the remote control won't switch operational modes.

If you selected the proper input source and there is still no sound, select the audio input signal for playback (see *Selecting the audio input signal* below).

#### 4 Press **AUTO/DIRECT** to select 'AUTO SURROUND' and start playback of the source.

If you're playing a Dolby Digital or DTS surround sound DVD disc, with a digital audio connection, you should hear surround sound. If you're playing a stereo source or if the connection is an analog audio connection, you will only hear sound from the front left/right speakers in the default listening mode.

It is possible to check on the front panel display whether or not surround sound playback is being performed properly. When using a surround back speaker, **DOD+PLIIx** is displayed when playing Dolby Digital 5.1-channel signals, and **DTS+NEO:6** is displayed when playing DTS 5.1-channel signals.

When not using a surround back speaker, **DOD** is displayed when playing Dolby Digital signals.

If the display does not correspond to the input signal and listening mode, check the connections and settings.

#### Note

- You may need to check the digital audio output settings on your DVD player or digital satellite receiver. It should be set to output Dolby Digital, DTS and 88.2 kHz/96 kHz PCM (2 channel) audio, and if there is an MPEG audio option, set this to convert the MPEG audio to PCM.
- Depending on your DVD player or source discs, you may only get digital 2 channel stereo and analog sound. In this case, the receiver must be set to a multichannel listening mode if you want multichannel surround sound.

#### 5 Use **MASTER VOLUME** to adjust the volume level.

Turn down the volume of your TV so that all sound is coming from the speakers connected to this receiver.

### Selecting the audio input signal

The audio input signal can be selected for each input source. Once it is set, the audio input that was selected will be applied whenever you select the input source using the input function buttons.

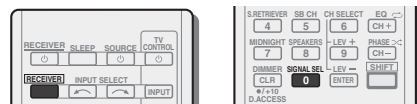

- Press **RECEIVER**, then press **SIGNAL SEL** to select the audio input signal corresponding to the source component. Each press cycles through the following:

- **H** – Selects an HDMI signal. **H** can be selected for **BD**, **DVD**, **DVR/BDR** or **VIDEO1** input. For other inputs, **H** cannot be selected.
  - When the **HDMI** option in *Setting the Audio options* on page 36 is set to **THRU**, the sound will be heard through your TV, not from this receiver.
- **A** – Selects the analog inputs.
- **C1/O1/O2** – Selects the digital input. The coaxial 1 input is selected for **C1**, and the optical 1 or 2 audio input is selected for **O1** or **O2**.

When **H** (HDMI) or **C1/O1/O2** (digital) is selected and the selected audio input is not provided, **A** (analog) is automatically selected.

#### Note

- **VIDEO1** input is fixed to **H** (HDMI). It cannot be changed.
- For the **TV/SAT** input, only **A** (analog) or **C1/O1/O2** (digital) can be selected. However, if the **ARC at HDMI Setup** is set to **ON**, the input is fixed to **H** (HDMI) and cannot be changed.
- When set to **H** (HDMI) or **C1/O1/O2** (digital), **DD** lights when a Dolby Digital signal is input, and **DTS** lights when a DTS signal is input.
- When the **H** (HDMI) is selected, the **A** and **DIGITAL** indicators are off (see page 7).

- When digital input (optical or coaxial) is selected, this receiver can only playback Dolby Digital, PCM (32 kHz to 96 kHz) and DTS (including DTS 96 kHz/24 bit) digital signal formats. The compatible signals via the HDMI terminals are: Dolby Digital, DTS, SACD (DSD 2 ch only), PCM (32 kHz to 192 kHz sampling frequencies), Dolby TrueHD, Dolby Digital Plus, DTS-EXPRESS, DTS-HD Master Audio and DVD Audio (including 192 kHz). With other digital signal formats, set to **A** (analog).

- You may get digital noise when a LD or CD player compatible with DTS is playing an analog signal. To prevent noise, make the proper digital connections (page 13) and set the signal input to **C1/O1/O2** (digital).
- Some DVD players don't output DTS signals. For more details, refer to the instruction manual supplied with your DVD player.

### Playing an iPod

This receiver has a dedicated iPod terminal that will allow you to control playback of audio content from your iPod using the controls of this receiver.

#### Important

- Pioneer cannot under any circumstances accept responsibility for any direct or indirect loss arising from any inconvenience or loss of recorded material resulting from the iPod failure.

#### Note

- This receiver is compatible with the audio and the video of the iPod nano, iPod (fifth generation), iPod classic, iPod touch and iPhone (only supports iPod (fifth generation) and iPod nano (first and second generation) audio playback) (iPod shuffle not supported). However, that some of the functions may be restricted for some models.
- This receiver has been developed and tested for the software version of iPod/iPhone/iPad indicated on the website of Pioneer (<http://pioneer.jp/homeav/support/ios/na/>).
- Installing software versions other than indicated on the website of Pioneer to your iPod/iPhone/iPad may result in incompatibility with this receiver.
- iPod and iPhone are licensed for reproduction of non-copyrighted materials or materials the user is legally permitted to reproduce.
- Features such as the equalizer cannot be controlled using this receiver, and we recommend switching the equalizer off before connecting.

#### 1 Switch on the receiver and your TV.

See *Connecting an iPod* on page 21.

#### 2 Switch the TV input so that it connects to the receiver.

#### 3 Press iPod USB on the remote control to switch the receiver to the iPod USB input.

The front panel display shows **Loading** while the receiver verifies the connection and retrieves data from the iPod.

#### 4 Use TOP MENU to display iPod Top menu.

When the display shows **Top Menu** you're ready to play music from the iPod.

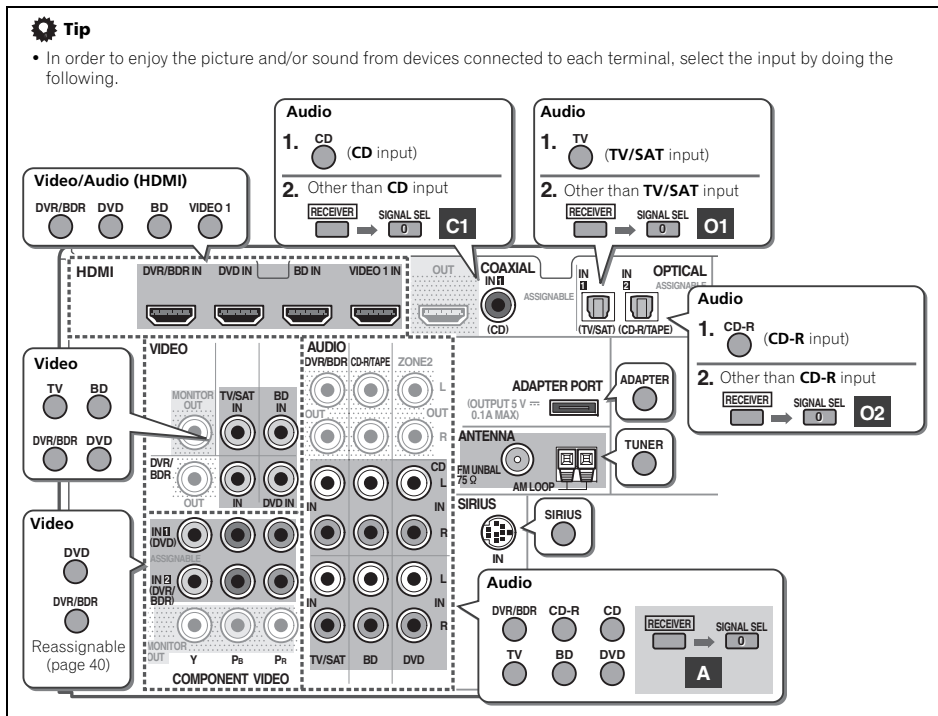





## Basic playback controls

This receiver's remote control buttons can be used for basic playback of files stored on USB devices.

- Press **iPod USB** to switch the remote control to the iPod/USB operation mode.

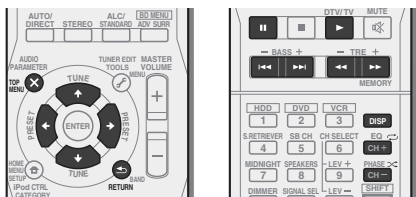

### Important

If a **USB Error** message lights in the display, try following the points below:

- Switch the receiver off, then on again.
- Reconnect the USB device with the receiver switched off.
- Select another input source (like **BD**), then switch back to **iPod USB**.
- Use a dedicated AC adapter (supplied with the device) for USB power.

For more information on error messages, see *USB messages* on page 52.

If this doesn't remedy the problem, it is likely your USB device is incompatible.

## Compressed audio compatibility

Note that although most standard bit/sampling rate combinations for compressed audio are compatible, some irregularly encoded files may not play back. The list below shows compatible formats for compressed audio files:

- MP3** (MPEG-1/2/2.5 Audio Layer 3) – Sampling rates: 8 kHz to 48 kHz; Bit rates: 8 kbps to 320 kbps (128 kbps or higher recommended); File extension: **.mp3**
- WMA** (Windows Media Audio) – Sampling rates: 32 kHz/44.1 kHz; Bit rates: 32 kbps to 192 kbps (128 kbps or higher recommended); File extension: **.wma**; WMA9 Pro and WMA lossless encoding: No
- AAC** (MPEG-4 Advanced Audio Coding) – Sampling rates: 11.025 kHz to 48 kHz; Bit rates: 16 kbps to 320 kbps (128 kbps or higher recommended); File extension: **.m4a**; Apple lossless encoding: No

## Other compatibility information

- VBR** (variable bit rate) MP3/WMA/MPEG-4 AAC playback: Yes (Note that in some cases playback time will not be displayed correctly.)
- DRM** (Digital Rights Management) protection compatible: Yes (DRM-protected audio files will not play in this receiver.)

## About MPEG-4 AAC

Advanced Audio Coding (AAC) is at the core of the MPEG-4 AAC standard, which incorporates MPEG-2 AAC, forming the basis of the MPEG-4 audio compression technology. The file format and extension used depend on the application used to encode the AAC file. This receiver plays back AAC files encoded by iTunes® bearing the extension '**.m4a**'. DRM-protected files will not play, and files encoded with some versions of iTunes® may not play.

*Apple and iTunes are trademarks of Apple Inc., registered in the U.S. and other countries.*

## About WMA

WMA is an acronym for Windows Media Audio and refers to an audio compression technology developed by Microsoft Corporation. This receiver plays back WMA files encoded using Windows Media® Player bearing the extension '**.wma**'. Note that DRM-protected files will not play, and files encoded with some versions of Windows Media® Player may not play.

## Bluetooth® ADAPTER for Wireless Enjoyment of Music

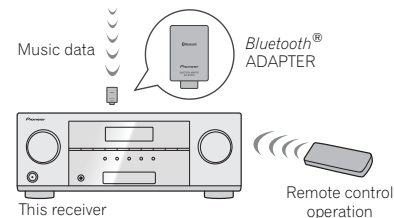
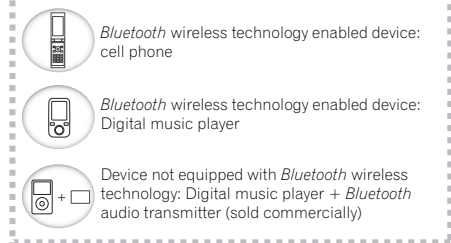

## Wireless music play

When the *Bluetooth* ADAPTER (Pioneer Model No. AS-BT100 or AS-BT200) is connected to this unit, a product equipped with *Bluetooth* wireless technology (portable cell phone, digital music player, etc.) can be used to listen to music wirelessly. Also, by using a commercially available transmitter supporting *Bluetooth* wireless technology, you can listen to music on a device not equipped with *Bluetooth* wireless technology. The AS-BT100 and AS-BT200 model supports SCMS-T contents protection, so music can also be enjoyed on devices equipped with SCMS-T type *Bluetooth* wireless technology.

- It must be necessary that the *Bluetooth* wireless technology enabled device supports A2DP profiles.

### Important

- Pioneer does not guarantee proper connection and operation of this unit with all *Bluetooth* wireless technology enabled devices.

### Remote control operation

The remote control supplied with this unit allows you to play and stop media, and perform other operations.

- It must be necessary that the *Bluetooth* wireless technology enabled device supports AVRCP profiles.
- Remote control operations cannot be guaranteed for all *Bluetooth* wireless technology enabled devices.

### Pairing the *Bluetooth* ADAPTER and *Bluetooth* wireless technology device

"Pairing" must be done before you start playback of *Bluetooth* wireless technology content using *Bluetooth* ADAPTER. Make sure to perform pairing first time you operate the system or any time pairing data is cleared. "Pairing" is the step necessary to register *Bluetooth* wireless technology device to enable *Bluetooth* communications. For more details, see also the operating instructions of your *Bluetooth* wireless technology device.

- Pairing is required when you first use *Bluetooth* wireless technology device and *Bluetooth* ADAPTER.
- To enable *Bluetooth* communication, pairing should be done with both of your system and *Bluetooth* wireless technology device.
- If the *Bluetooth* wireless technology device's security code is "0000", there is no need to make the security code setting on the receiver. Press **ADAPTER** to switch the **ADAPTER** input, then conduct the pairing operation on the *Bluetooth* wireless technology device. If pairing is successful, there is no need to performing the pairing operation below.
- When using the AS-BT200 only: If the *Bluetooth* wireless technology device supports SSP (Secure Simple Pairing), there is no need to make the security code setting. Press **ADAPTER** to switch the **ADAPTER** input, then conduct the pairing operation on the *Bluetooth* wireless technology device. If pairing is successful, there is no need to performing the pairing operation below.

- 1 Press **TOP MENU**.
- 2 Press **ENTER** to enter **PAIRING**.
- 3 Select the **PIN code to be used from 0000/1234/8888** using **←/→**, then press **ENTER**. **PAIRING** blinks.

- You can use any of 0000/1234/8888 PIN codes. *Bluetooth* wireless technology device using any other PIN code cannot be used with this system.

- 4 Switch on the *Bluetooth* wireless technology device that you want to make pairing, place it near the system and set it into the pairing mode.

- 5 Check to see that the *Bluetooth* ADAPTER is detected by the *Bluetooth* wireless technology device.

When *Bluetooth* wireless technology device is connected:

*Bluetooth* wireless technology device name appears in the receiver display.

- The system can display alphanumeric characters only. Other characters may not be displayed correctly.

When *Bluetooth* wireless technology device is not connected:

**NODEVICE** appears in the receiver display. In this case, perform the connection operation from the side of the *Bluetooth* wireless technology device.

- 6 From the *Bluetooth* wireless technology device list, select *Bluetooth* ADAPTER and enter the **PIN code selected in the step 4**.

- PIN code may in some case be referred to as **PASSKEY**.

### Listening to Music Contents of *Bluetooth* wireless technology device with Your System

- 1 Press **ADAPTER** to switch the receiver to **ADAPTER** input.

The **ADAPTER** input can also be selected by pressing **SOUND RETRIEVER AIR** on the front panel. In this case, **S.R AIR**, the optimum listening mode, is selected automatically.

- 2 Perform the connection operation from the side of the *Bluetooth* wireless technology device to the *Bluetooth* ADAPTER.

- When the *Bluetooth* ADAPTER is not plugged into the **ADAPTER PORT** terminal, **NO ADAPTER** will be displayed if **ADAPTER** input is selected.

- 3 Start playback of music contents stored in *Bluetooth* wireless technology device.

This receiver's remote control buttons can be used for basic playback of files stored on the *Bluetooth* wireless technology device.

- *Bluetooth* wireless technology device should be compatible with AVRCP profile.
- Depending on *Bluetooth* wireless technology device you use, operation may differ from what is shown in the remote control buttons.



The *Bluetooth*® word mark and logos are registered trademarks owned by Bluetooth SIG, Inc. and any use of such marks by PIONEER CORPORATION is under license. Other trademarks and trade names are those of their respective owners.

### Listening to Satellite Radio

To listen to Satellite Radio, you'll need to connect a SIRIUS Satellite Radio tuner (sold separately) to your Sirius-Ready receiver. SIRIUS Satellite Radio is available to residents of the US (except Alaska and Hawaii) and Canada.

Satellite Radio delivers a variety of commercial-free music from categories ranging from Pop, Rock, Country, R&B, Dance, Jazz, Classical and many more plus coverage of all the top professional and college sports including play by play games from select leagues and teams. Additional programming includes expert sports talk, uncensored entertainment, comedy, family programming, local traffic and weather and news from your most trusted sources.

Once you've purchased a SIRIUS tuner you'll need to activate it and subscribe to begin enjoying the service. Easy to follow installation and setup instructions are provided with the SIRIUS tuner. There are a variety of programming packages available, including the option of adding 'The Best of XM'

programming to the SIRIUS service. The 'Best of XM' service is not available to SIRIUS Canada subscribers at this time. Please check with SIRIUS Canada for any updates using the numbers and web address below.

Family friendly packages are also available to restrict channels featuring content that may be inappropriate for children.

To subscribe to SIRIUS, U.S. and Canadian customers can call 1-888-539-SIRI (1-888-539-7474) or visit [siriuscanada.ca](http://siriuscanada.ca) (Canada).

SIRIUS, XM and all related marks and logos are trademarks of Sirius XM Radio Inc. and its subsidiaries. All rights reserved.

Service not available in Alaska and Hawaii.

## Listening to SIRIUS Radio

After connecting, you will be able to use this receiver to select channels using the front panel display.

### Note

- In order to activate your radio subscription, you will need the SIRIUS ID (SID) which uniquely identifies your tuner. The SID may be found on a sticker located on the packaging, or on the bottom of the tuner itself. The label will have a printed 12-digit SID number. When you have located the SID, write it down in the space provided near the end of this manual. Connect SIRIUS on the internet at: <https://activate.siriusradio.com>

Follow the prompts to activate your subscription, or you can also call SIRIUS toll-free at 1-888-539-SIRIUS (1-888-539-7474).

- Press **SIRIUS** to switch to the SIRIUS input.

For best reception, you may need to move the SiriusConnect tuner antenna near a window (refer to the manual for the SiriusConnect Home tuner for antenna placement recommendations).

- If after pressing **SIRIUS** the display shows **Antenna Error**, try disconnecting the antenna and reconnecting. If the display shows **Check Sirius Tuner**, check the connection of the AC adapter and this receiver to the SiriusConnect tuner.

- You can check the strength of reception by pressing **DISP (DISPLAY)**.

## Selecting channels and browsing by genre

Use the front panel display to select channels. You can select channels from your favorite genre.

- You can, however, use just the front panel display to do everything if you prefer.
- Press **↑/↓** to select the channel. In the next 2 seconds, the radio broadcast is automatically tuned in.
  - To select a channel from your favorite genre, press **CATEGORY** and use **←/→** to select a genre, and then use **↑/↓** and **ENTER** to select a channel from the selected genre.
    - Select **SR000 (SIRIUS ID)** from the front panel display to check the Radio ID of the SIRIUS Connect tuner.
  - To cancel and exit any time, press **RETURN**.

### Tip

- You can select channels directly by pressing **D.ACCESS** then the three-digit channel number.
- You can press **DISP (DISPLAY)** to change SIRIUS Radio information in the front panel display.
- The currently selected channel is automatically chosen (without pressing **ENTER**) after 2 seconds.

## Saving channel presets

This receiver can memorize up to 30 channels, stored.

### 1 Select the channel you want to memorize.

See *Selecting channels and browsing by genre* above.

### 2 Press T.EDIT.

The display shows a blinking memory number.

### 3 Press ←/→ to select the channel preset you want.

You can also use the number buttons to select a preset.

### 4 Press ENTER.

After pressing **ENTER**, the preset number stop blinking and the receiver stores the SIRIUS channel.

## Listening to channel presets

You will need to have some presets stored to do this.

- Press **←/→** to select the channel preset you want.
  - You can also use the number buttons on the remote control to recall the channel preset.

## Using the SIRIUS Menu

The SIRIUS Menu provides additional SIRIUS Radio features.

### 1 Press TOP MENU.

### 2 Use ↑/↓ to select a menu item then press ENTER.

Choose between the following menu items:

- All CHANNEL SKIP CLEAR** – Clear the channel skip function set by the SiriusConnect tuner. If the channel skip function is not cleared here, not all channels are displayed because this receiver stores the channels set for skipping in the SiriusConnect tuner.
- Parental Lock** – Use **↑/↓** and **ENTER** to select channels you would like to place under parental lock. Channels put under parental lock are not displayed in the Channel Guide, but may be accessed by directly inputting their channel number and providing the parental lock password.
- Password Set** – Set the parental lock password.

### 3 When you're finished press TOP MENU to return to the reception display.

- You can reset the channel presets, parental lock and Password Set in *Resetting the main unit* on page 52.



## Chapter 5: Listening to your system

### Choosing the listening mode

This receiver offers a variety of listening modes to accommodate playback of various audio formats. Choose one according to your speaker environment or the source.

- While listening to a source, press the listening mode button repeatedly to select a listening mode you want.

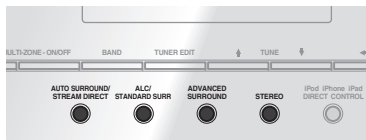
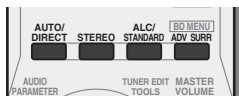

- The listening mode is shown on the display on the front panel.

#### Important

- The listening modes and many features described in this section may not be available depending on the current source, settings and status of the receiver.

### Auto playback



The simplest, most direct listening option is the **AUTO SURROUND** feature. With this, the receiver automatically detects what kind of source you're playing and selects multichannel or stereo playback as necessary.

- Press **AUTO/DIRECT** repeatedly until **AUTO SURROUND** shows briefly in the display (it will then show the decoding or playback format). Check the digital format indicators in the display to see how the source is being processed.

#### Note

- Stereo surround (matrix) formats are decoded accordingly using **NEO:6 CINEMA** or **DOLBY PLIIx MOVIE** (see *Listening in surround sound* below for more on these decoding formats).
- When listening to the **ADAPTER** input, the **S.R AIR** feature is selected automatically (see *Using the Advanced surround* on page 34 for more on this).

### Listening in surround sound



Using this receiver, you can listen to any source in surround sound. However, the options available will depend on your speaker setup and the type of source you're listening to.

- If the source is Dolby Digital, DTS, or Dolby Surround encoded, the proper decoding format will automatically be selected and shows in the display.

When you select **STEREO ALC** (Auto Level Control stereo mode), this unit equalizes playback sound levels if each sound level varies with the music source recorded in a portable audio player.

When you select **STEREO**, you will hear the source through just the front left and right speakers (and possibly your subwoofer depending on your speaker settings). Dolby Digital and DTS multichannel sources are downmixed to stereo.

The following modes provide basic surround sound for stereo and multichannel sources.

#### Explanatory notes

No: No connected / Yes: Connected / Two: Two speakers are connected / -: Whether connected or no

Type of surround modes	Suitable sources	Surround back speaker(s)	Front height speakers
<b>Two channel sources</b>			
<b>STEREO ALC</b>	See above.	-	-
<b>DOLBY PLIIx MOVIE</b>	Movie	Yes <sup>a</sup>	No
<b>DOLBY PLII MOVIE</b>		No	-
<b>DOLBY PLIIx MUSIC<sup>b</sup></b>	Music	Yes <sup>a</sup>	No
<b>DOLBY PLII MUSIC<sup>b</sup></b>		No	-
<b>DOLBY PLIIx GAME</b>	Video games	Yes <sup>a</sup>	No
<b>DOLBY PLII GAME</b>		No	-
<b>DOLBY PLIIz HEIGHT<sup>c</sup></b>	Movie/Music	No	Yes
<b>NEO:6 CINEMA<sup>d</sup></b>	Movie	-	-
<b>NEO:6 MUSIC<sup>d</sup></b>	Music	-	-
<b>DOLBY PRO LOGIC</b>	Old movies	-	-
Straight Decode <sup>e</sup>	No additional effects	No	-
<b>STEREO<sup>f</sup></b>	See above.	-	-
<b>Multichannel sources</b>			
<b>STEREO ALC</b>	See above.	-	-
<b>DOLBY PLIIx MOVIE</b>	Movie	Two <sup>a</sup>	No
<b>DOLBY PLII MOVIE</b>		No	-
<b>DOLBY PLIIx MUSIC<sup>b</sup></b>	Music	Two <sup>a</sup>	No
<b>DOLBY PLII MUSIC<sup>b</sup></b>		No	-
<b>DOLBY DIGITAL EX</b>	Movie/Music	Yes	No
<b>DTS-E5</b>	Movie/Music	Yes	No
<b>DTS NEO:6</b>	Movie/Music	Yes	No
<b>DOLBY PLIIz HEIGHT</b>	Movie/Music	No	Yes
Straight Decode <sup>e</sup>	No additional effects	-	-
<b>STEREO<sup>f</sup></b>	See above.	-	-

- If surround back channel processing (page 35) is switched off, or the surround back speakers are set to **NO DOLBY PLIIX** becomes **DOLBY PLIIX** (5.1 channel sound).
- You can also adjust the **C.WIDTH**, **DIMEN.**, and **PNRM.** effect (see *Setting the Audio options* on page 36).
- You can also adjust the **H.GAIN** effect (see *Setting the Audio options* on page 36).
- You can also adjust the **C.IMG** effect (see *Setting the Audio options* on page 36).
- Cannot be selected when the **Speaker System** is set to **Surr. Back** (see *The Speaker System setting* on page 41).
- You can choose the **STEREO** mode by using **STEREO** button.
  - The audio is heard with your surround settings and you can still use the Midnight, Loudness, Phase Control, Sound Retriever and Tone functions.

#### Note

- In modes that give 6.1 channel sound, the same signal is heard from both surround back speakers.

### Using the Advanced surround



The Advanced surround feature creates a variety of surround effects. Try different modes with various soundtracks to see which you like.

<b>ACTION</b>	Designed for action movies with dynamic soundtracks.
<b>DRAMA</b>	Designed for movies with lots of dialog.
<b>ENT.SHOW</b>	Suitable for musical sources.
<b>ADVANCED GAME</b>	Suitable for video games.
<b>SPORTS</b>	Suitable for sports programs.
<b>CLASSICAL</b>	Gives a large concert hall-type sound
<b>ROCK/POP</b>	Creates a live concert sound for rock and/ or pop music.
<b>UNPLUGGED</b>	Suitable for acoustic music sources.
<b>EXT.STEREO</b>	Gives multichannel sound to a stereo source, using all of your speakers

### F.S.S.ADVANCE

(Front Stage Surround ADVANCE)

Allows you to create natural surround sound effects using just the front speakers and the subwoofer.

Use to provide a rich surround sound effect directed to the center of where the front left and right speakers sound projection area converges.

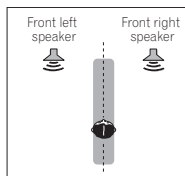

**S.R AIR**  
(Sound Retriever AIR)

Suitable for listening to the sound from a *Bluetooth* wireless technology device. The **S.R AIR** listening mode can only selected when the **ADAPTER** input.

**PHONES SURR**

When listening through headphones, you can still get the effect of overall surround.

### Using Stream Direct



Use the Stream Direct modes when you want to hear the truest possible reproduction of a source. All unnecessary signal processing is bypassed.

See *Auto playback* on page 33.

**AUTO SURROUND**

**DIRECT**

Sources are heard according to the settings made in the Manual SP Setup (speaker setting, channel level, speaker distance), as well as with dual mono settings. You will hear sources according to the number of channels in the signal.

Phase Control, Acoustic Calibration EQ, Sound Delay, Auto Delay, LFE Attenuate and Center image functions are available.

**PURE DIRECT**

Analog and PCM sources are heard without any digital processing.

### Using the Sound Retriever

When audio data is removed during the compression process, sound quality often suffers from an uneven sound image. The Sound Retriever feature employs new DSP technology that helps bring CD quality sound back to compressed 2-channel audio by restoring sound pressure and smoothing jagged artifacts left over after compression.

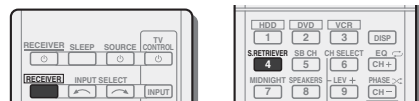

- Press **RECEIVER**, then press **S.RETRIEVER** to switch the **S.RTV (Sound Retriever) ON** or **OFF**.

#### Note

- The Sound Retriever is only applicable to 2-channel sources.

### Listening with Acoustic Calibration EQ

You can listen to sources using the Acoustic Calibration Equalization set in *Automatically setting up for surround sound (MCACC)* on page 24. Refer to these pages for more on Acoustic Calibration Equalization.

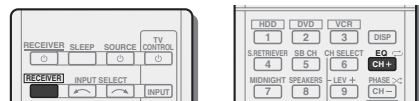

- While listening to a source, press **RECEIVER**, then press **EQ** to switch the **EQ (Acoustic Calibration EQ) ON** or **OFF**.

The MCACC indicator on the front panel lights when Acoustic Calibration EQ is active.

- You can't use Acoustic Calibration EQ with Stream Direct mode and it has no effect with headphones.

## Better sound using Phase Control

This receiver's Phase Control feature uses phase correction measures to make sure your sound source arrives at the listening position in phase, preventing unwanted distortion and/or coloring of the sound.

Phase Control technology provides coherent sound reproduction through the use of phase matching for an optimal sound image at your listening position. The default setting is on and we recommend leaving Phase Control switched on for all sound sources.



- Press **RECEIVER**, then press **PHASE** to switch the P.CTL (Phase Control) ON or OFF.

### Note

- Phase matching is a very important factor in achieving proper sound reproduction. If two waveforms are 'in phase', they crest and trough together, resulting in increased amplitude, clarity and presence of the sound signal. If a crest of a wave meets a trough, then the sound will be 'out of phase' and an unreliable sound image will be produced.
- If your subwoofer has a phase control switch, set it to the plus (+) sign (or 0°). However, the effect you can actually feel when Phase Control is set to **ON** on this receiver depends on the type of your subwoofer. Set your subwoofer to maximize the effect. It is also recommended you try changing the orientation or the place of your subwoofer.
- Set the built-in lowpass filter switch of your subwoofer to OFF. If this cannot be done on your subwoofer, set the cutoff frequency to a higher value.
- If the speaker distance is not properly set, you may not have a maximized Phase Control effect.
- The Phase Control mode cannot be set to **ON** in the following cases:
  - When the **PURE DIRECT** mode is switched on.
  - When the headphones are connected.

## Using surround back channel processing

You can have the receiver automatically use 6.1 or 7.1 decoding for 6.1 encoded sources (for example, Dolby Digital EX or DTS-ES), or you can choose to always use 6.1 or 7.1 decoding (for example, with 5.1 encoded material). With 5.1 encoded sources, a surround back channel will be generated, but the material may sound better in the 5.1 format for which it was originally encoded (in which case, you can simply switch surround back channel processing off).

- With a 7.1-channel surround system, audio signals that have undergone matrix decoding processing through surround back channel processing to which the Up Mix function is added are output from the surround back speakers.

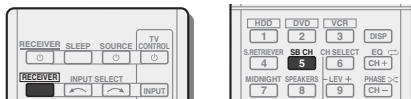

- Press **RECEIVER**, then press **SB CH** repeatedly to cycle the surround back channel options.

Each press cycles through the options as follows:

- **SB ON** – Matrix decoding processing for generating the surround back component from the surround component is turned on.
- **SB AUTO** – Matrix decoding processing for generating the surround back component from the surround component is switched automatically. Matrix decoding processing is only performed when surround back channel signals are detected in the input signals.
- **SB OFF** – Matrix decoding processing for generating the surround back component from the surround component is turned off.

## Setting the Up Mix function

In a 7.1-channel surround system with surround speakers placed directly at the sides of the listening position, the surround sound of 5.1-channel sources is heard from the side. The Up Mix function mixes the sound of the surround speakers with the surround back speakers so that the surround sound is heard from diagonally to the rear as it should be.

- Using the Up Mix function is effective when the speakers in the 7.1-channel surround system are set up as recommended in the example on page 10.
- Depending on the positions of the speakers and the sound source, in some cases it may not be possible to achieve good results. In this case, set the setting to **OFF**.

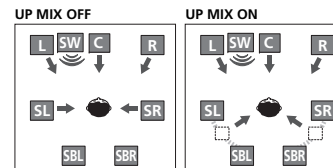

- 1 Switch the receiver into standby.
- 2 While holding down **PRESET** → on the front panel, and hold the **STANDBY/ON** for about two seconds. **UP MIX: OFF** appears and the Up Mix function turns off. If you want to turn this function on, perform steps 1 and 2 again.

- When set to **ON**, the (Up Mix) indicator on the front panel lights.

### Note

- Set to **ON** regardless of this setting when playing DTS-HD signals.
- May automatically be set to **OFF** even when set to **ON**, depending on the input signal and listening mode.

## Setting the Audio options

There are a number of additional sound settings you can make using the **AUDIO PARAMETER** menu. The defaults, if not stated, are listed in bold.

### Important

- Note that if a setting doesn't appear in the **AUDIO PARAMETER** menu, it is unavailable due to the current source, settings and status of the receiver.

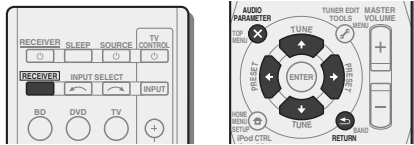

**1** Press **RECEIVER**, then press **AUDIO PARAMETER** button.

**2** Use **↑/↓** to select the setting you want to adjust.

Depending on the current status/mode of the receiver, certain options may not be able to be selected. Check the table below for notes on this.

**3** Use **←/→** to set it as necessary.

See the table below for the options available for each setting.

**4** Press **RETURN** to confirm and exit the menu.

Setting/What it does	Option(s)
<b>EQ</b> (Acoustic Calibration EQ) Switches on/off the effect of Acoustic Calibration EQ.	<b>ON</b>  <i>OFF</i>
<b>S.DELAY</b> (Sound Delay) Some monitors have a slight delay when showing video, so the soundtrack will be slightly out of sync with the picture. By adding a bit of delay, you can adjust the sound to match the presentation of the video.	0.0 to 9.0 (frames)  1 second = 30 frames (NTSC) Default: <b>0.0</b>

Setting/What it does	Option(s)
<b>MIDNIGHT/LOUDNESS</b> <sup>a</sup> The <b>MIDNIGHT</b> allows you to hear effective surround sound of movies at low volumes. The <b>LOUDNESS</b> is used to get good bass and treble from music sources at low volumes.	<b>M/L OFF</b>  <i>MIDNIGHT</i>  <i>LOUDNESS</i>
<b>S.RTV</b> (Sound Retriever) <sup>b</sup> When audio data is removed during the WMA/MP3 <sup>c</sup> compression process, sound quality often suffers from an uneven sound image. The Sound Retriever feature employs new DSP technology that helps bring CD quality sound back to compressed 2-channel audio by restoring sound pressure and smoothing jagged artifacts left over after compression.	<b>OFF</b> <sup>d</sup>  <i>ON</i>
<b>DUAL MONO</b> <sup>e</sup> Specifies how dual mono encoded Dolby Digital soundtracks should be played.	<b>CH1</b> – Channel 1 is heard only  <b>CH2</b> – Channel 2 is heard only  <b>CH1 CH2</b> – Both channels heard from front speakers
<b>F.PCM</b> (Fixed PCM) This is useful if you find there is a slight delay before <b>OFF</b> recognizes the PCM signal on a CD, for instance. When <b>ON</b> is selected, noise may be output during playback of non-PCM sources. Please select another input signal if this is a problem.	<b>OFF</b>  <i>ON</i>
<b>DRC</b> (Dynamic Range Control) Adjusts the level of dynamic range for movie soundtracks optimized for Dolby Digital, DTS, Dolby Digital Plus, Dolby TrueHD, DTS-HD and DTS-HD Master Audio (you may need to use this feature when listening to surround sound at low volumes).	<b>AUTO</b> <sup>f</sup>  <i>MAX</i>  <i>MID</i>  <i>OFF</i>

Setting/What it does	Option(s)
<b>LFE ATT</b> (LFE Attenuate) Some Dolby Digital and DTS audio sources include ultra-low bass tones. Set the LFE attenuator as necessary to prevent the ultra-low bass tones from distorting the sound from the speakers. The LFE is not limited when set to 0 dB, which is the recommended value. When set to -15 dB, the LFE is limited by the respective degree. When OFF is selected, no sound is output from the LFE channel.	<b>0</b> (0 dB)  <i>5 (-5 dB)</i>  <i>10 (-10 dB)</i>  <i>15 (-15 dB)</i>  <i>20 (-20 dB)</i>  <b>** (OFF)</b>
<b>SACD G.</b> (SACD Gain) <sup>g</sup> Brings out detail in SACDs by maximizing the dynamic range (during digital processing).	<b>0</b> (0 dB)  <i>+6 (+6 dB)</i>
<b>HDMI</b> (HDMI Audio) Specifies the routing of the HDMI audio signal out of this receiver ( <b>AMP</b> ) or through to a TV ( <b>THRU</b> ). When <b>THRU</b> is selected, no sound is output from this receiver.	<b>AMP</b>  <i>THRU</i>
<b>A.DLY</b> (Auto Delay) <sup>h</sup> This feature automatically corrects the audio-video delay between components connected with an HDMI cable. The audio delay time is set depending on the operational status of the display connected with an HDMI cable. The video delay time is automatically adjusted according to the audio delay time.	<b>OFF</b>  <i>ON</i>
<b>C.WIDTH</b> (Center Width) <sup>i</sup> (Applicable only when using a center speaker) Spreads the center channel between the front right and left speakers, making it sound wider (higher settings) or narrower (lower settings).	0 to 7 Default: <b>3</b>
<b>DIMEN</b> (Dimension) <sup>j</sup> Adjusts the surround sound balance from front to back, making the sound more distant (minus settings), or more forward (positive settings).	-3 to +3 Default: <b>0</b>



Setting/What it does	Option(s)
----------------------	-----------

<b>PNRM.</b> (Panorama) <sup>i</sup> Extends the front stereo image to include surround speakers for a 'wraparound' effect.	<b>OFF</b>  <i>ON</i>
--	-----------------------------

<b>C.IMG</b> (Center Image) <sup>j</sup> (Applicable only when using a center speaker) Adjust the center image to create a wider stereo effect with vocals. Adjust the effect from <b>0</b> (all center channel sent to front right and left speakers) to <b>10</b> (center channel sent to the center speaker only).	<b>0</b> to <b>10</b> Default: <b>3</b> (NEO:6 MUSIC), <b>10</b> (NEO:6 CINEMA)
--	---

<b>H.GAIN</b> (Height Gain) Adjusts the output from the front height speaker when listening in <b>DOLBY PLIIz</b> <b>HEIGHT</b> mode. If set to <b>H</b> , the sound from the top will be more emphasized.	<i>L (Low)</i> <b>M (Mid)</b> <i>H (High)</i>
---	---

- You can change the MIDNIGHT/LOUDNESS options at any time by using **MIDNIGHT** button.
- You can change the Sound Retriever feature at any time by using **S.RETRIEVER** button.
- WMA and MP3 playback available only via **iPod USB** input.
- The default setting when the **iPod USB** or **ADAPTER** input is selected is **ON**.
- This setting works only with dual mono encoded Dolby Digital and DTS soundtracks.
- The initial set **AUTO** is only available for Dolby TrueHD signals. Select **MAX** or **MID** for signals other than Dolby TrueHD.
- You shouldn't have any problems using this with most SACD discs, but if the sound distorts, it is best to switch the gain setting back to **0** dB.
- This feature is only available when the connected display supports the automatic audio/video synchronizing capability ("lip-sync") for HDMI. If you find the automatically set delay time unsuitable, set **A.DLY** to **OFF** and adjust the delay time manually. For more details about the lip-sync feature of your display, contact the manufacturer directly.
- Only available with 2-channel sources in **DOLBY PLII MUSIC** mode.
- Only when listening to 2-channel sources in **NEO:6 CINEMA** and **NEO:6 MUSIC** mode.

## Making an audio or a video recording

You can make an audio or a video recording from the built-in tuner, or from an audio or video source connected to the receiver (such as a CD player or TV).

Only video signals that were input to this receiver through a composite video cable or analog audio inputs can be recorded. Signals that were input through an HDMI cable, component video cable or digital audio cable (see *Connecting other audio components* on page 19 for more on connections).

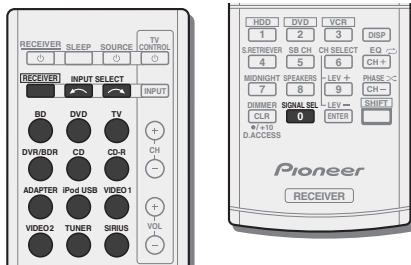

### 1 Press input function buttons to select the input function you want to record.

The input of the receiver will switch over, and you will be able to operate other components using the remote control.

- The input source can also be selected by using **INPUT SELECT** buttons on the remote control, or by using the front panel **INPUT SELECTOR** dial.

### 2 Select the audio input signal (if necessary).

Press **RECEIVER** then press **SIGNAL SEL** and select the analog inputs (**A**) for the source component of which you want to record (see page 26 for more on this).

### 3 Prepare the source you want to record.

Tune to the radio station, load the CD, video, DVD etc.

### 4 Prepare the recorder.

Insert a blank tape, MD, video etc. into the recording device and set the recording levels.

Refer to the instructions that came with the recorder if you are unsure how to do this. Most video recorders set the audio recording level automatically—check the component's instruction manual if you're unsure.

## 5 Start recording, then start playback of the source component.

### Note

- The receiver's volume, balance, tone (bass, treble, loudness), and surround effects have no effect on the recorded signal.
- Some video sources are copy-protected. These cannot be recorded.

## Chapter 6: The System Setup menu

### Using the System Setup menu

The following section shows you how to make detailed settings to specify how you're using the receiver, and also explains how to fine-tune individual speaker system settings to your liking.

#### Important

- If headphones are connected to the receiver, disconnect them.
- You can't use the System Setup menu when the **iPod USB** input is selected.

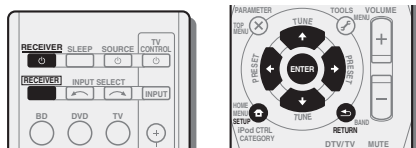

#### 1 Switch on the receiver and your TV.

Press **RECEIVER** to switch on.

#### 2 Switch the TV input so that it connects to the receiver.

#### 3 Press **RECEIVER**, then press **SETUP**.

The System Setup menu appears on your TV. Use **↑/↓/←/→** and **ENTER** on the remote control to navigate through the screens and select menu items. Press **RETURN** to confirm and exit the current menu.

- Press **SETUP** at any time to exit the System Setup menu.

#### 4 Select the setting you want to adjust.

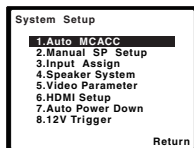

- **Auto MCACC** – This is a quick and effective automatic surround setup (see *Automatically setting up for surround sound (MCACC)* on page 24).
- **Manual SP Setup**
  - **Speaker Setting** – Specify the size and number of speakers you've connected (see below).
  - **Crossover Network** – Specify which frequencies will be sent to the subwoofer (page 39).
  - **Channel Level** – Adjust the overall balance of your speaker system (page 39).
  - **Speaker Distance** – Specify the distance of your speakers from the listening position (page 40).
- **Input Assign** – Specify what you've connected to the component video inputs (see *The Input Assign menu* on page 40).
- **Speaker System** – Specifies how you are using the speaker terminals (see *The Speaker System setting* on page 41).
- **Video Parameter**
  - **Video Converter** – Converts video signals for output from the HDMI OUT terminal for all video types (page 41).
  - **Resolution** – Specifies the output resolution of the video signal (page 41).
  - **Aspect** – Specifies the aspect ratio (page 42).
- **HDMI Setup** – Sets synchronized operations when connected to a device/TV that supports the **Control** with HDMI function (see *HDMI Setup* on page 43).
- **Auto Power Down** – Sets to automatically turn off the power when the receiver has not operated for several hours (see *The Auto Power Down menu* on page 42).
- **12V Trigger** – Sets the input function that enables the signal output from the 12 V trigger terminal (see *The 12 V Trigger Setting* on page 42).

### Manual speaker setup

This section allows you to make detailed settings to optimize the surround sound performance. You only need to make these settings once (unless you change the placement of your current speaker system or add new speakers).

These settings are designed to fine-tune your system, but if you're satisfied with the settings made in *Automatically setting up for surround sound (MCACC)* on page 24, it isn't necessary to make all of these settings.

#### CAUTION

- The test tones used in the System Setup are output at high volume.

#### Important

- Depending on the **Speaker System** setting, there will be differences in the speaker items that can be adjusted. The OSD display for these operating instructions is an example of when the **Speaker System** setting is set to **Surr. Back**.

### Speaker Setting

Use this setting to specify your speaker configuration (size, number of speakers). It is a good idea to make sure that the settings made in *Automatically setting up for surround sound (MCACC)* on page 24 are correct.

#### 1 Select 'Manual SP Setup' from the System Setup menu.

#### 2 Select 'Speaker Setting' from the Manual SP Setup menu.

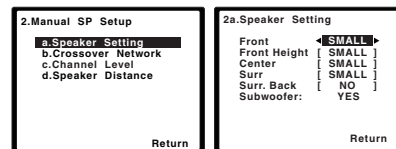

#### 3 Choose the set of speakers that you want to set then select a speaker size.

Use **←/→** to select the size (and number) of each of the following speakers:

- **Front** – Select **LARGE** if your front speakers reproduce bass frequencies effectively, or if you didn't connect a subwoofer. Select **SMALL** to send the bass frequencies to the subwoofer.
- **Center** – Select **LARGE** if your center speaker reproduces bass frequencies effectively, or select **SMALL** to send bass frequencies to the other speakers or subwoofer. If you didn't connect a center speaker, choose **NO** (the center channel is sent to the other speakers).
- **Front Height** – Select **LARGE** if your front height speakers reproduce bass frequencies effectively. Select **SMALL** to send bass frequencies to the other speakers or subwoofer. If you didn't connect front height speakers choose **NO**.
- **Surr** – Select **LARGE** if your surround speakers reproduce bass frequencies effectively. Select **SMALL** to send bass frequencies to the other speakers or subwoofer. If you didn't connect surround speakers choose **NO** (the sound of the surround channels is sent to the other speakers).
- **Surr. Back** – Select the number of surround back speakers you have (one, two or none). Select **LARGE** if your surround back speakers reproduce bass frequencies effectively. Select **SMALL** to send bass frequencies to the other speakers or subwoofer. If you didn't connect surround back speakers choose **NO**.
  - When using only one surround back speaker, connect it to the **SURROUND BACK L (Single)** terminals.
- **Subwoofer** – LFE signals and bass frequencies of channels set to **SMALL** are output from the subwoofer when **YES** is selected (see notes below). Choose the **PLUS** setting if you want the subwoofer to output bass sound continuously or you want deeper bass (the bass frequencies that would normally come out the front and center speakers are also routed to the subwoofer). If you did not connect a subwoofer choose **NO** (the bass frequencies are output from other speakers).

**4 When you're finished, press RETURN.**  
You return to the Manual SP Setup menu.

**Note**

- If you select **SMALL** for the front speakers, the subwoofer will automatically be fixed to **YES**. Also, the center, surround, surround back and front height speakers can't be set to **LARGE** if the front speakers are set to **SMALL**. In this case, all bass frequencies are sent to the subwoofer.
- If the surround speakers are set to **NO**, the surround back speakers will automatically be set to **NO**.
- If you have a subwoofer and like lots of bass, it may seem logical to select **LARGE** for your front speakers and **PLUS** for the subwoofer. This may not, however, yield the best bass results. Depending on the speaker placement of your room you may actually experience a decrease in the amount of bass due to low frequency cancellations. In this case, try changing the position or direction of speakers. If you can't get good results, listen to the bass response with it set to **PLUS** and **YES** or the front speakers set to **LARGE** and **SMALL** alternatively and let your ears judge which sounds best. If you're having problems, the easiest option is to route all the bass sounds to the subwoofer by selecting **SMALL** for the front speakers.

**Crossover Network**

- Default setting: **100Hz**

This setting decides the cutoff between bass sounds playing back from the speakers selected as **LARGE**, or the subwoofer, and bass sounds playing back from those selected as **SMALL**. It also decides where the cutoff will be for bass sounds in the LFE channel.

- For more on selecting the speaker sizes, see *Speaker Setting* on page 38.

- 1 Select 'Manual SP Setup' from the System Setup menu.
- 2 Select 'Crossover Network' from the Manual SP Setup menu.

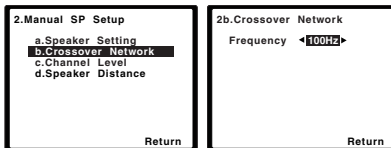

**3 Choose the frequency cutoff point.**

Frequencies below the cutoff point will be sent to the subwoofer (or **LARGE** speakers).

**4 When you're finished, press RETURN.**

You return to the Manual SP Setup menu.

**Channel Level**

Using the channel level settings, you can adjust the overall balance of your speaker system, an important factor when setting up a home theater system.

- 1 Select 'Manual SP Setup' from the System Setup menu.
- 2 Select 'Channel Level' from the Manual SP Setup menu.

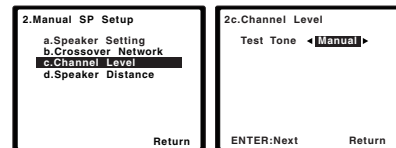

**3 Select a setup option.**

- **Manual** – Move the test tone manually from speaker to speaker and adjust individual channel levels.
- **Auto** – Adjust channel levels as the test tone moves from speaker to speaker automatically.

**4 Confirm your selected setup option.**

The test tones will start after you press **ENTER**. After the volume increases to the reference level, test tones will be output.

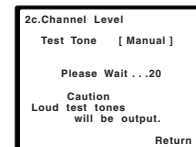

### 5 Adjust the level of each channel using $\leftarrow/\rightarrow$ .

If you selected **Manual**, use  $\uparrow/\downarrow$  to switch speakers. The **Auto** setup will output test tones in the order shown on-screen:

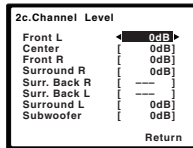

Adjust the level of each speaker as the test tone is emitted.

#### Note

- If you are using a Sound Pressure Level (SPL) meter, take the readings from your main listening position and adjust the level of each speaker to 75 dB SPL (C-weighting/slow reading).
- The subwoofer test tone is output at low volumes. You may need to adjust the level after testing with an actual soundtrack.

### 6 When you're finished, press RETURN.

You return to the Manual SP Setup menu.

#### Tip

- You can change the channel levels at any time by press **RECEIVER**, then press **CH SELECT** and **LEV +/-** on the remote control. You can also press **CH SELECT** and use  $\uparrow/\downarrow$  to select the channel, and then use  $\leftarrow/\rightarrow$  to adjust the channel levels.

### Speaker Distance

For good sound depth and separation from your system, you need to specify the distance of your speakers from the listening position. The receiver can then add the proper delay needed for effective surround sound.

- 1 Select 'Manual SP Setup' from the System Setup menu.
- 2 Select 'Speaker Distance' from the Manual SP Setup menu.

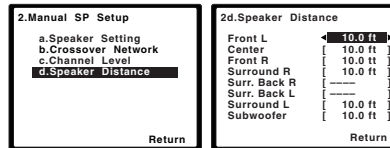

### 3 Adjust the distance of each speaker using $\leftarrow/\rightarrow$ .

You can adjust the distance of each speaker in 0.1 feet increments.

### 4 When you're finished, press RETURN.

You return to the Manual SP Setup menu.

### The Input Assign menu

You only need to make settings in the Input Assign menu if you didn't hook up your equipment according to the default settings for the component video inputs.

- Default settings:
  - Component-1: DVD
  - Component-2: DVR (DVR/BDR)

#### Important

- If you connect any source component to the receiver using a component video input, you should have your TV connected to this receiver's **COMPONENT VIDEO MONITOR OUT** or **HDMI OUT** output (down converting component video is not possible after assigning an input).

If you didn't make component video connections according to the defaults above, you must assign the numbered input to the component you've connected (or else you may see the video signal of a different component). For more on this, see *Using the component video jacks* on page 19.

### 1 Select 'Input Assign' from the System Setup menu.

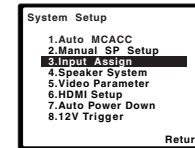

### 2 Select 'Component Input' from the Input Assign menu.

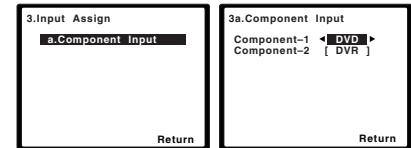

### 3 Select the number of the component video input to which you've connected your video component.

The numbers correspond with the numbers beside the inputs on the rear of the receiver.

### 4 Select the component that corresponds with the one you connected to that input.

Select between **BD**, **DVD**, **TV (TV/SAT)**, **DVR (DVR/BDR)** or **OFF**.

- Use  $\leftarrow/\rightarrow$  and **ENTER** to do this.
- If you assign a component input to a certain function, any component inputs previously assigned to that function will automatically be switched off.
- Make sure you have connected the audio from the component to the corresponding inputs on the rear of the receiver.

### 5 When you're finished, press RETURN.

You return to the Input Assign menu.

- For the assignment of the digital signal inputs, see *Selecting the audio input signal* on page 26.

## The Speaker System setting

Specify either using the surround back speaker (or the speaker B), or the front height speaker connection with the B-speaker terminals.

- Default setting: **Surr. Back**

### 1 Select 'Speaker System' from the System Setup menu.

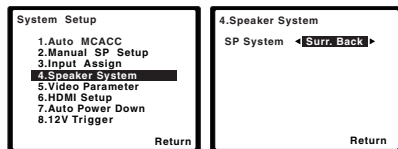

### 2 Select the speaker system setting using ←/→.

- **Surr. Back** – Sound is output from the surround back speaker or the speaker B.
- **Height** – Sound is output from front height speaker.

### 3 When you're finished, press RETURN.

You return to the System Setup menu.

## The Video Parameter setting

This receiver can up-convert the video signal input from the composite/component video terminals; the output is from the HDMI OUT terminal. The following shows the various settings for this function.

### Video Converter

This setting specifies valid/invalid for the function that converts the input video signal from each composite/component video terminal. When **OFF** is selected, Resolution and Aspect can not be set.

### 1 Select 'Video Parameter' from the System Setup menu.

### 2 Select 'Video Converter' from the Video Parameter menu.

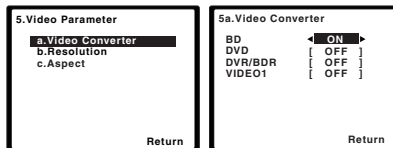

### 3 Select the setting for converting each type of video input.

- **ON** – The signal is output also to the HDMI OUT terminal.
- **OFF** – The signal input from the HDMI terminal of the selected input function will be output from the HDMI OUT terminal. The signal input from the analog composite video and the component video will not be output from the HDMI OUT terminal.

### 4 When you're finished, press RETURN.

You return to the Video Parameter menu.

## Resolution

Specifies the output resolution of the video signal (when video input signals are output at the HDMI OUT terminal, select this according to the resolution of your monitor and the images you wish to watch).

### 1 Select 'Video Parameter' from the System Setup menu.

### 2 Select 'Resolution' from the Video Parameter menu.

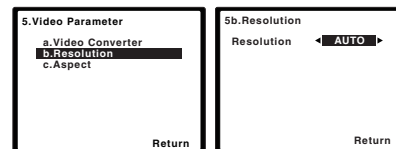

### 3 Select output resolution.

- **AUTO** – The resolution is selected automatically according to the capacity of the TV (monitor) connected by HDMI.
- **PURE** – The signals are output with the same resolution as when input.
- **480p/720p/1080i/1080p** – The signal is output with the resolution specified here (**480p** means the resolution of 480p/576p).

### 4 When you're finished, press RETURN.

You return to the Video Parameter menu.

#### Note

- When set to a resolution with which the TV (monitor) is not compatible, no picture is output. Also, in some cases no picture will be output due to copyright protection signals. In this case, change the setting.
- When a display is connected by HDMI, if this is set to something other than **PURE** and 480i/576i analog signals are input, 480p/576p signals are output from the component output terminals.

## Aspect

Specifies the aspect ratio when analog video input signals are output at the HDMI OUT terminal. Make your desired settings while checking each setting on your display (if the image doesn't match your monitor type, cropping or black bands appear).

- 1 Select 'Video Parameter' from the System Setup menu.
- 2 Select 'Aspect' from the Video Parameter menu.

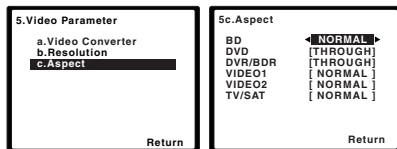

- 3 Select desired output aspect ratio.

- **THROUGH** – The input video signal is output unchanged.
- **NORMAL** – Black bands will appear either at top and bottom or on both sides.

- 4 When you're finished, press RETURN.

You return to the Video Parameter menu.

### Note

- If the image doesn't match your monitor type, adjust the aspect ratio on the source component or on the monitor.

## The Auto Power Down menu

Set to automatically turn off the receiver after a specified time has passed (when the power has been on with no operation for several hours).

- Default setting: **OFF**

- 1 Select 'Auto Power Down' from the System Setup menu.

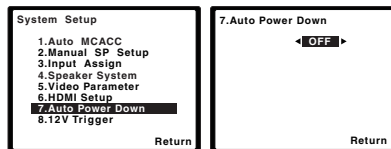

- 2 Specify the amount of time to allow before the power is turned off (when there has been no operation).

- You can select 2, 4 or 6 hours, or **OFF** (if no automatic shutoff is desired).

- 3 When you're finished, press RETURN.

You return to the System Setup menu.

### Note

- Turning the power off using the Auto Power Down will apply to both the main zone and the sub zone. However, if the **Control** at **HDMI Setup** is set to **ON**, the Auto Power Down may not work in the sub zone.

## The 12 V Trigger Setting

If the input switches over to the input function set here, a control signal is output from the receiver's 12 V trigger terminal, and operations such as power coupling with other devices and equipment can be achieved.

- 1 Select '12V Trigger' from the System Setup menu.

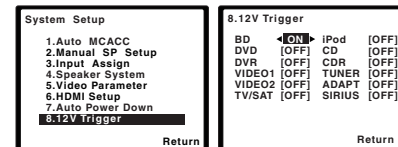

- 2 Choose the setting of the 12 V trigger output coupling for each input function.

- 3 When you're finished, press RETURN.

You return to the System Setup menu.

## Chapter 7: Control with HDMI function

Synchronized operations below with a **Control** with HDMI-compatible Pioneer TV or Blu-ray Disc player or with a component of another make that supports the **Control** with HDMI functions are possible when the component is connected to the receiver using an HDMI cable.

### • Synchronized amp mode

The receiver's volume can be set and the sound can be muted using the TV's remote control.

### • Power synchronization with TV

### • Automatic switching of inputs

The receiver's input switches over automatically when the TV's input is changed or a **Control** with HDMI-compatible component is played.

### 👉 Important

- With Pioneer devices, the **Control** with HDMI functions are referred to as "KURO LINK".
- You cannot use this function with components that do not support **Control** with HDMI.
- We only guarantee this receiver will work with Pioneer made **Control** with HDMI-compatible components and components of other makes that support the **Control** with HDMI function. However, we do not guarantee that all synchronized operations will work with components of other makes that support the **Control** with HDMI function.
- Use a High Speed HDMI® cable when you want to use the **Control** with HDMI function. The **Control** with HDMI function may not work properly if a different type of HDMI cable is used.
- For details about concrete operations, settings, etc., refer to also the operating instructions for each component.

## Making Control with HDMI connections

You can use synchronized operation for a connected TV and up to four other components.

- Be sure to connect the TV's audio cable to the audio input of this unit. When the TV and receiver are connected by HDMI connections, if the TV supports the HDMI Audio Return Channel function, the sound of the TV is input to the receiver via the HDMI terminal, so there is no need to connect an audio cable. In this case, set **ARC** at **HDMI Setup** to **ON** (see *HDMI Setup* below).

For details, see *Connecting using HDMI* on page 15.

### 👉 Important

- When connecting this system or changing connections, be sure to switch the power off and disconnect the power cord from the wall socket. After completing all connections, connect the power cords to the wall socket.
- After this receiver is connected to an AC outlet, a 2 second to 10 second HDMI initialization process begins. You cannot carry out any operations during initialization. The HDMI indicator on the display unit blinks during initialization, and you can turn this receiver on once it has stopped blinking.
- To get the most out of this function, we recommend that you connect your HDMI component not to a TV but rather directly to the HDMI terminal on this receiver.
- While the receiver is equipped with four HDMI inputs, the **Control** with HDMI function can only be used with up to three DVD or Blu-ray Disc players or up to three DVD or Blu-ray Disc recorders.

## HDMI Setup

You must adjust the settings of this receiver as well as the connected **Control** with HDMI-compatible components in order to make use of the **Control** with HDMI function. For more information see the operating instructions for each component.

### 1 Switch on the receiver and your TV.

Press **RECEIVER** to switch on.

### 2 Switch the TV input so that it connects to the receiver.

### 3 Press **[RECEIVER]**, then press **SETUP**.

The System Setup menu appears on your TV. Use **↑/↓/←/→** and **ENTER** on the remote control to navigate through the screens and select menu items. Press **RETURN** to confirm and exit the current menu.

- Press **SETUP** at any time to exit the System Setup menu.

### 4 Select 'HDMI Setup' from the System Setup menu.

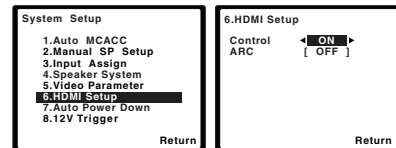

### 5 Select the 'Control' setting you want.

Choose whether to set this unit's **Control** with HDMI function **ON** or **OFF**. You will need to set it to **ON** to use the **Control** with HDMI function.

When using a component that does not support the **Control** with HDMI function, set this to **OFF**.

- **ON** – Enables the **Control** with HDMI function. When this unit's power is turned off and you have a supported source begin playback while using the **Control** with HDMI function, the audio and video outputs from the HDMI connection are output from the TV.
- **OFF** – The **Control** with HDMI is disabled. Synchronized operations cannot be used. When this unit's power is turned off, audio and video of sources connected via HDMI are not output.

**6 Select the 'ARC' setting you want.**

When a TV supporting the HDMI Audio Return Channel function is connected to the receiver, the sound of the TV can be input via the HDMI terminal.

- **ON** – The TV's sound is input via the HDMI terminal. This can only be selected when **Control** is set to **ON**.
- **OFF** – The TV's sound is input from the audio input terminals other than HDMI inputs.

**7 When you're finished, press RETURN.**

You return to the System Setup menu.

**Before using synchronization**

Once you have finished all connections and settings, you must:

- 1 Put all components into standby mode.**
- 2 Turn the power on for all components, with the power for the TV being turned on last.**
- 3 Choose the HDMI input to which the TV is connected to this receiver, and see if video output from connected components displays properly on the screen or not.**
- 4 Check whether the components connected to all HDMI inputs are properly displayed.**

**About synchronized operations**

The **Control** with HDMI-compatible component connected to the receiver operates in sync as described below.

- **Synchronized amp mode**
  - From the menu screen of the **Control** with HDMI-compatible TV, set audio to be played through this receiver, and the receiver will switch to the synchronized amp mode.
  - When in the synchronized amp mode, the synchronized amp mode is canceled when the receiver's power is turned off. To turn the synchronized amp mode back on, set audio to be played through the receiver from the TV's menu screen, etc. This receiver will power up and switch to the synchronized amp mode.

- When in the synchronized amp mode, the synchronized amp mode is canceled if an operation that produces sound from the TV is performed from the TV's menu screen, etc.

- When the synchronized amp mode is canceled, the receiver's power turns off if you were viewing an HDMI input or a TV program on the TV.

• **Power synchronization with TV**

- When the TV's power is set to standby, the receiver's power is also set to standby. (Only when the input for a component connected to the receiver by HDMI connection is selected or when watching the TV.)

• **Automatic switching of inputs**

- The receiver's input switches automatically when the **Control** with HDMI-compatible component is played.
- The receiver's input switches automatically when the TV's input is switched.
- The synchronized amp mode remains in effect even if the receiver's input is switched to a component other than one connected by HDMI.

**About connections with a product of a different brand that supports the Control with HDMI function**

The synchronized operations below can be used when the receiver's **Control** with HDMI function is connected to a TV of a brand other than Pioneer that supports the **Control** with HDMI function. (Depending on the TV, however, some of the **Control** with HDMI functions may not work.)

- When the TV's power is set to standby, the receiver's power is also set to standby. (Only when the input for a component connected to the receiver by HDMI connection is selected or when watching the TV)
- The sound of TV programs or an external input connected to the TV can also be output from the speakers connected to the receiver. (If the TV does not support the HDMI Audio Return Channel function, this requires connection of an optical digital cable, etc., in addition to the HDMI cable.)

The synchronized operations below can be used when the receiver's **Control** with HDMI function is connected to a player or recorder of a brand other than Pioneer that supports the **Control** with HDMI function.

- When playback starts on the player or recorder, the receiver's input switches to the HDMI input to which that component is connected.

See the Pioneer website for the latest information on the models of non-Pioneer brands and products that support the **Control** with HDMI function.

**Cautions on the Control with HDMI function**

- Connect the TV and components (Blu-ray Disc player, etc.) directly to this receiver. Interrupting a direct connection with other amps or an AV converter (such as an HDMI switch) can cause operational errors.
- When the receiver's **Control** is turned **ON**, even if the receiver's power is in the standby mode, it is possible to output the audio and video signals from a player via HDMI to the TV without producing sound from the receiver, but only when a **Control** with HDMI-compatible component (Blu-ray Disc player, etc.) and compatible TV are connected. In this case, the receiver's power turns on and the power and **HDMI** indicators light.



## Chapter 8: Using the MULTI-ZONE feature

### MULTI-ZONE listening

This receiver can power up to two independent systems in separate rooms after you have made the proper MULTI-ZONE connections.

Different sources can be playing in two zones at the same time or, depending on your needs, the same source can also be used. The main and sub zones have independent power (the main zone power can be off while the sub zone is on) and the sub zone can be controlled by the remote or front panel controls.

### Making MULTI-ZONE connections

It is possible to make these connections if you have a separate speakers for your sub zone (**ZONE 2**). You will also need a separate amplifier for your sub zone.

#### Note

- You can't use sound controls (such as the bass/treble controls or Midnight listening) or any surround modes with a separate amplifier in the sub zone. You can, however, use the features available with your sub zone amplifier

### MULTI-ZONE listening options

The following table shows what you can listen to in the sub zone:

Sub Zone	Input sources available
<b>ZONE 2</b>	The built-in tuner and other analog audio sources.

### Basic MULTI-ZONE setup

- Connect a separate amplifier to the **ZONE 2 AUDIO OUT** jacks on the rear of this receiver.

You should have a pair of speakers attached to the sub zone amplifier as shown in the following illustration.

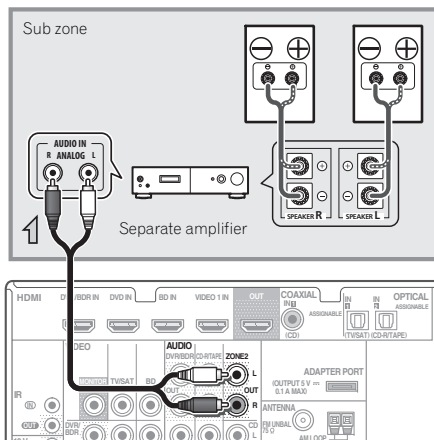

### Using the MULTI-ZONE controls

The following steps use the front panel controls to select sources. See *MULTI-ZONE remote controls* below.



- Press the **MULTI-ZONE ON/OFF** button on the front panel.

Each press selects a MULTI-ZONE option:

- ZONE 2 ON** – Switches the MULTI-ZONE feature on
- ZONE 2 OFF** – Switches the MULTI-ZONE feature off

The **ZONE** indicator lights when the MULTI-ZONE control has been switched ON.

- Press **CONTROL**.

- When the receiver is on, make sure that any operations for the sub zone are done while **ZONE 2** shows in the display. If this is not showing, the front panel controls affect the main zone only. If the receiver is in standby, the display is dimmed, and **ZONE2 ON** continues to show in the display.

- Use the **INPUT SELECTOR** dial to select the source for the zone you have selected.

For example, **Z2: CDR** sends the source connected to the **CDR** inputs to the sub room (**ZONE 2**).

- If you select **TUNER**, you can use the tuner controls to select a preset station (see *Saving station presets* on page 32 if you're unsure how to do this). The tuner cannot be tuned to more than one station at a time. Therefore, changing the station in one zone also changes the station in the other zone. Please be careful not to change stations when recording a radio broadcast.

- When you're finished, press **CONTROL** again to return to the main zone controls.

You can also press the **MULTI-ZONE ON/OFF** button on the front panel to switch off all output to the sub zone.

#### Note

- You won't be able to switch the main zone off completely unless you've switched off the MULTI-ZONE control first.
- If you don't plan to use the MULTI-ZONE feature for a while, turn off the power in both the sub and main rooms so that this receiver is in standby.
- Volume level cannot be adjusted with this receiver. Use the separate amplifier connected to the **ZONE2 OUT** to adjust the volume.

### MULTI-ZONE remote controls

Press the **[RECEIVER]** button on the remote control, then with the **SHIFT** button pressed, press the buttons below to operate the corresponding zone.

The following table shows the possible MULTI-ZONE remote controls:

Button	What it does
<b>RECEIVER</b>	Switches on/off power in the sub zone.
<b>INPUT SELECT</b>	Use to select the input source in the sub zone.
<b>Input function buttons</b>	Use to select the input source directly in the sub zone.

## Chapter 9: Controlling the rest of your system

### Setting the remote to control other components

Most components can be assigned to one of the input function buttons using the component's manufacturer preset code stored in the remote.

However, please note that there are cases where only certain functions may be controllable after assigning the proper preset code, or the codes for the manufacturer in the remote control will not work for the model that you are using.

#### Note

- **TV CONTROL** buttons are only dedicated to control the TV (for example, codes for TV, CATV, Satellite TV or DTV).
- You can cancel or exit any of the steps by pressing **RECEIVER**.
- After one minute of inactivity, the remote automatically exits the operation.

### Selecting preset codes directly

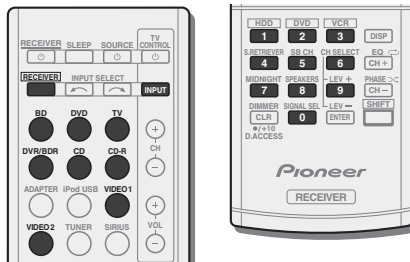

**1** While pressing **RECEIVER**, press and hold the '1' button for three seconds.

**2** Press the input function button for the component you want to control.

The component can be assigned to the **BD, DVD, TV, DVR/BDR, CD, CD-R, VIDEO1** or **VIDEO2** button.

- When assigning preset codes to **TV CONTROL**, press **INPUT** here.

**3** Use the number buttons to enter the preset code.

You can find the preset codes on page 47.

If the correct code has been input the power of the component being input will turn on or off.

The power of the component being input will only turn on or off if that component is able to be turned on directly by remote control.

**4** Repeat steps 2 through 3 to try a different code, or to enter a code for another component you want to control.

**5** When you're done, press **RECEIVER**.

### Clearing all the remote control settings

You can clear all presets and restore the factory default settings.

- While pressing **RECEIVER**, press and hold the '0' button for three seconds.

### Default preset codes

Input function button	Preset code
BD	2 2 5 5
DVD	2 2 5 6
TV	0 2 9 1
DVR/BDR	2 2 5 7
CD	5 0 0 0
CD-R	5 0 0 1
VIDEO1	6 0 9 9
VIDEO2	1 0 5 3
TV CONTROL	0 2 9 1

## Controls for TVs

This remote control can control components after entering the proper codes or teaching the receiver the commands (see *Controlling the rest of your system* on page 46 for more on this). Use the input function buttons to select the component.

- The **TV CONTROL** buttons on the remote control are dedicated to control the TV assigned to the **TV CONTROL INPUT** button.

Button(s)	Function	TV	DTV	Satellite/ Cable TV
<b>TV CONTROL</b> ○	Switches the DTV on or off. Switches the TV or CATV between standby and on.	-	✓	-
<b>TV CONTROL INPUT</b>	Switches the TV input. (Not possible with all models.)	✓	-	-
<b>TV CONTROL CH +/-</b>	Selects channels.	✓	✓	✓
<b>TV CONTROL VOL +/-</b>	Adjust the TV volume.	✓	✓	✓
○ <b>SOURCE</b>	Press to switch the component assigned to the <b>TV</b> button on or off.	✓	✓	✓
<b>DTV/TV</b>	Switches between the DTV and analog TV input modes for Pioneer TVs.	✓	✓	-
<b>HOME MENU</b>	Use as the <b>GUIDE</b> button for navigating.	✓	✓	✓
<b>RETURN</b>	Use to select closed captioning with DTV.	-	✓	-
Number buttons	Use to select a specific TV channel.	✓	✓	✓
<b>ENTER</b>	Use to enter a channel.	✓	✓	✓
<b>MENU</b>	Press to display the DTV menu. Select the menu screen.	-	✓	-
↑/↓/←/→/ <b>ENTER</b>	Press to select or adjust and navigate items on the menu screen.	✓	✓	✓
<b>CH +/-</b>	Selects channels.	✓	✓	✓

## Controls for other components

This remote control can control these components (BD, DVD, CD, DVR (BDR), VCR, CD-R) after entering the proper codes or teaching the receiver the commands (see *Controlling the rest of your system* on page 46 for more on this). Use the input function buttons to select the component.

Button(s)	Function
○ <b>SOURCE</b>	Press to switch the component between standby and on.
◀◀	Press to return to the start of the current track. Repeated presses skips to the start of previous tracks.
▶▶	Press to advance to the start of the next track. Repeated presses skips to the start of following tracks.
	Pause playback or recording.
▶	Start playback.
▶▶▶	Hold down for fast forward playback.
◀◀◀	Hold down for fast reverse playback.
■	Stops playback (on some models, pressing this when the disc is already stopped will cause the disc tray to open).
Number buttons	Use to enter a title/chapter/track number.
<b>DISP</b>	Press to display information.
<b>TOP MENU</b>	Displays the disc 'top' menu of a BD/DVD player.
<b>MENU</b>	Displays menus for the current BD/DVD or DVR you are using.
↑/↓/←/→/ <b>ENTER/RETURN</b>	Navigates BD/DVD menu/options.
<b>HOME MENU</b>	Displays the HOME MENU.
<b>CH +/-</b>	Selects channels. (DVR/VCR only)

Button(s)	Function
<i>For HDD/DVD/VCR recorder</i>	
<b>HDD (SHIFT + 1)</b>	Switches to the hard disk controls.
<b>DVD (SHIFT + 2)</b>	Switches to the DVD controls.
<b>VCR (SHIFT + 3)</b>	Switches to the VCR controls.

## Preset Code List

You should have no problem controlling a component if you find the manufacturer in this list, but please note that there are cases where codes for the manufacturer in the list will not work for the model that you are using. There are also cases where only certain functions may be controllable after assigning the proper preset code.

### Important

- We do not guarantee the operations of all the manufacturers and devices listed. Operation may not be possible even if a preset code is entered.

*example:*

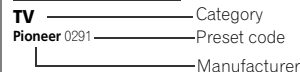

## TV

**Pioneer** 0291, 0113, 0294, 0296  
**Admiral** 0001, 0014  
**Adventura** 0012  
**Aiwa** 0002  
**Akai** 0002, 0100  
**Albatron** 0097  
**Alleron** 0009  
**America Action** 0104  
**Amtron** 0008  
**Anam** 0104  
**Anam National** 0003, 0008  
**AOC** 0004, 0005, 0006, 0100  
**Apex** 0021, 0102, 0106  
**Audiovox** 0008, 0104  
**Aventura** 0103  
**Axion** 0094  
**Bang & Olufsen** 0111  
**Belcor** 0004  
**Bell & Howell** 0001  
**Benq** 0054  
**Bradford** 0008, 0104  
**Brilliant** 0109  
**Brockwood** 0004  
**Broksonic** 0104  
**Candle** 0004, 0006, 0012, 0100  
**Carnivale** 0100  
**Carver** 0110  
**CCE** 0110  
**Celebrity** 0002  
**Celera** 0106  
**Changhong** 0106  
**Citizen** 0004, 0006, 0008, 0100  
**Clarion** 0104  
**Coby** 0056  
**Colytyme** 0004, 0006  
**Concerto** 0004, 0006  
**Contec** 0104  
**Contec/Cony** 0007, 0008  
**Craig** 0008, 0104  
**Crosley** 0081, 0101  
**Crown** 0008, 0104  
**CTX** 0063  
**Curtis Mathes** 0000, 0004, 0006, 0014, 0100, 0101  
**CXC** 0008, 0104  
**Cytron** 0053  
**Daewoo** 0004, 0005, 0006, 0023  
**Daytron** 0004 0006  
**Dell** 0073  
**DiamondVision** 0096  
**Dimensia** 0000  
**Disney** 0046  
**Dumont** 0004, 0011, 0099  
**Durabrand** 0001, 0103, 0104  
**Dwin** 0104  
**Electroband** 0002  
**Electrograph** 0107

**Electrohome** 0002, 0003, 0004, 0006  
**Element** 0082  
**Emerson** 0004, 0006, 0007, 0008, 0009, 0023, 0103, 0104  
**Emprex** 0092  
**Envision** 0004, 0006, 0100  
**Epson** 0061  
**ESA** 0103  
**Fujitsu** 0009  
**Funai** 0008, 0009, 0103, 0104  
**Futuretech** 0008, 0104  
**Gateway** 0067, 0107, 0108  
**GE** 0000, 0003, 0004, 0006, 0010, 0016, 0039  
**GFM** 0080, 0084  
**Gibraltar** 0004, 0011, 0099, 0100  
**Net-TV** 0107  
**Nikko** 0006, 0100  
**Norcent** 0060  
**Olevia** 0048, 0054, 0059  
**Onwa** 0008, 0104  
**Oppo** 0095  
**Optimus** 0105  
**Optoma** 0075  
**Optonica** 0014  
**Orion** 0025  
**Panasonic** 0003, 0010, 0100, 0107, 0227, 0105, 0114  
**Penney** 0100, 0102  
**Philco** 0003, 0004, 0005, 0006, 0007, 0100, 0101  
**Philips** 0003, 0004, 0007, 0019, 0020, 0101  
**Philips Magnavox** 0019  
**Pilot** 0004, 0100  
**Polaroid** 0057, 0106  
**Portland** 0004, 0005, 0006  
**Prima** 0065  
**Princeton** 0097  
**JC Penney** 0000, 0004, 0005, 0006, 0010  
**Proscan** 0000  
**Proton** 0004, 0006, 0007  
**Protron** 0055  
**Proview** 0068  
**Pulsar** 0004, 0011, 0099  
**Quasar** 0003, 0010, 0105  
**Radio Shack** 0100, 0104  
**Radio Shack/Realistic** 0000, 0004, 0006, 0007, 0008  
**RCA** 0000, 0003, 0004, 0005, 0006, 0013, 0024, 0035  
**Realistic** 0100, 0104  
**Runco** 0011, 0099, 0100  
**Sampo** 0004, 0006, 0100, 0107  
**Samsung** 0004, 0005, 0006, 0007, 0022, 0032, 0076, 0077, 0083, 0100, 0110  
**Sansui** 0025  
**Sanyo** 0004, 0050  
**Sceptre** 0072

**Megapower** 0097  
**Megatron** 0006  
**Memorex** 0001, 0005, 0006, 0007  
**MGA** 0004, 0005, 0006, 0100  
**Midland** 0010, 0011, 0099  
**Mintek** 0091  
**Mitsubishi** 0004, 0005, 0006, 0014, 0045  
**Motorvision** 0097  
**Montgomery Ward** 0001  
**Motorola** 0003, 0014  
**MTC** 0004, 0005, 0006, 0100  
**Multitech** 0008, 0104, 0110  
**NAD** 0006, 0102  
**NEC** 0003, 0004, 0005, 0006, 0100  
**Net-TV** 0107  
**Nikko** 0006, 0100  
**Norcent** 0060  
**Olevia** 0048, 0054, 0059  
**Onwa** 0008, 0104  
**Oppo** 0095  
**Optimus** 0105  
**Optoma** 0075  
**Optonica** 0014  
**Orion** 0025  
**Panasonic** 0003, 0010, 0100, 0107, 0227, 0105, 0114  
**Penney** 0100, 0102  
**Philco** 0003, 0004, 0005, 0006, 0007, 0100, 0101  
**Philips** 0003, 0004, 0007, 0019, 0020, 0101  
**Philips Magnavox** 0019  
**Pilot** 0004, 0100  
**Polaroid** 0057, 0106  
**Portland** 0004, 0005, 0006  
**Prima** 0065  
**Princeton** 0097  
**JC Penney** 0000, 0004, 0005, 0006, 0010  
**Proscan** 0000  
**Proton** 0004, 0006, 0007  
**Protron** 0055  
**Proview** 0068  
**Pulsar** 0004, 0011, 0099  
**Quasar** 0003, 0010, 0105  
**Radio Shack** 0100, 0104  
**Radio Shack/Realistic** 0000, 0004, 0006, 0007, 0008  
**RCA** 0000, 0003, 0004, 0005, 0006, 0013, 0024, 0035  
**Realistic** 0100, 0104  
**Runco** 0011, 0099, 0100  
**Sampo** 0004, 0006, 0100, 0107  
**Samsung** 0004, 0005, 0006, 0007, 0022, 0032, 0076, 0077, 0083, 0100, 0110  
**Sansui** 0025  
**Sanyo** 0004, 0050  
**Sceptre** 0072

**Scotch** 0006  
**Scott** 0004, 0006, 0007, 0008, 0009, 0090, 0104  
**Sears** 0000, 0004, 0006, 0009, 0101, 0102, 0103  
**Sharp** 0004, 0006, 0007, 0014, 0053  
**Sheng Chia** 0014  
**Shogun** 0004  
**Signature** 0001  
**Sony** 0002, 0018, 0029, 0030, 0031, 0034  
**Soundesign** 0004, 0006, 0008, 0009, 0104  
**Squareview** 0103  
**SSS** 0004, 0008, 0104  
**Starlite** 0008, 0104  
**Superscan** 0014  
**Supre-Macy** 0012  
**Supreme** 0002  
**SVA** 0088  
**Sylvania** 0004, 0006, 0049, 0079, 0080, 0100, 0101, 0103  
**Symphonic** 0008, 0041, 0103, 0104  
**Syntax** 0054  
**Syntax-Brilliant** 0054  
**Tandy** 0014  
**Tatung** 0003, 0109  
**Technics** 0010, 0105  
**Techwood** 0004, 0006, 0010  
**Teknika** 0001, 0004, 0005, 0006, 0007, 0008, 0009, 0101, 0104  
**TMK** 0004, 0006  
**TNCI** 0099  
**Toshiba** 0026, 0028, 0036, 0038, 0040, 0043, 0102  
**Vector Research** 0100  
**Vidikon** 0101  
**Vidtech** 0004, 0005, 0006  
**Viewsonic** 0058, 0107  
**Viking** 0012  
**Viore** 0089  
**Vizio** 0004, 0070, 0071, 0108  
**Wards** 0000, 0001, 0004, 0005, 0006, 0009, 0100, 0101  
**Waycon** 0102  
**Westinghouse** 0047, 0051  
**White Westinghouse** 0023  
**Yamaha** 0004, 0005, 0006, 0100  
**Zenith** 0001, 0004, 0011, 0015, 0099

## DVD

*If operations are not possible using the preset codes below, you may be able to conduct operations with the preset codes for the BD, DVR (BDR, HDR).*

**Pioneer** 2256, 2014  
**Accurian** 2092  
**Advent** 2072  
**Aiwa** 2012  
**Aki** 2066  
**Alco** 2070  
**Allegro** 2087  
**Amphion MediaWorks** 2037  
**AMW** 2037  
**Apex** 2002, 2018, 2079, 2080  
**Apple** 2058  
**Arrgo** 2088  
**Aspire** 2073  
**Astar** 2052  
**Audiovox** 2070  
**Auxion** 2040  
**Bang & Olufsen** 2081  
**Blaupunkt** 2080  
**Blue Parade** 2078  
**Boston** 2059  
**Broksonic** 2066  
**California Audio Labs** 2068  
**CambridgeSoundWorks** 2068  
**CineVision** 2087  
**Coby** 2029  
**Curtis Mathes** 2089  
**CyberHome** 2000, 2088  
**Cytron** 2039  
**Daewoo** 2021, 2087  
**Denon** 2026, 2068  
**Desay** 2055  
**DiamondVision** 2042  
**Disney** 2022  
**Durabrand** 2090  
**Emerson** 2067, 2082, 2091  
**Enterprise** 2082  
**ESA** 2063, 2049, 2048  
**Fisher** 2083  
**Funai** 2091  
**GE** 2016, 2077, 2080  
**GFM** 2043  
**Go Video** 2080  
**Gradiente** 2068  
**Greenhill** 2080  
**Haier** 2054  
**Hamman/Kardon** 2030, 2084  
**Hitachi** 2011  
**Hiteker** 2079  
**ilive** 2062  
**IO** 2038  
**Initial** 2038, 2080

**Insignia** 2036, 2064, 2091

**Integra** 2078

**Improny** 2060

**JVC** 2034

**JVC** 2013

**Kawasaki** 2070

**Kenwood** 2028, 2068

**KLH** 2070, 2080

**Koss** 2024, 2069, 2075

**Landel** 2093

**Lasonic** 2085

**Lennox** 2074, 2090

**LG** 2019, 2051, 2061, 2082, 2087

**Liquid Video** 2075

**Liteon** 2025, 2092

**Magnavox** 2067, 2076, 2091

**Memorex** 2066

**Microsoft** 2077

**Mintek** 2038, 2080, 2086

**Mitsubishi** 2020

**Nesa** 2080

**Next Base** 2093

**Nextech** 2066

**Onkyo** 2076

**Oppo** 2041, 2057

**Oritron** 2069, 2075

**Panasonic** 2005, 2007, 2017, 2032, 2033, 2050, 2068, 2076

**Philips** 2045, 2076

**Proced** 2079

**Proscan** 2077

**Qwestar** 2069

**RCA** 2008, 2016, 2070, 2077, 2078, 2080

**Regent** 2074

**Rio** 2087

**Rowa** 2071

**Samsung** 2009, 2011, 2015, 2031, 2044, 2068

**Sansui** 2066

**Sanyo** 2066, 2083

**Sharp** 2035

**Sherwood** 2063

**Shinonic** 2086

**Sonic Blue** 2087

**Sony** 2003, 2004, 2010, 2012, 2027, 2046, 2047, 2048

**Sungale** 2054

**Superscan** 2067

**Sylvania** 2023, 2067, 2091

**Symphonic** 2023, 2067

**Teac** 2070

**Technics** 2068

**Theta Digital** 2078

**Toshiba** 2001, 2006, 2049, 2066, 2076

**Truban** 2000

**Urban Concepts** 2076

**US Logic** 2086

**Venturer** 2070

**Xbox** 2077

**Yamaha** 2005, 2068

**Zenith** 2019, 2076, 2082, 2087

## BD

*If operations are not possible using the preset codes below, you may be able to conduct operations with the preset codes for the DVD, DVR (BDR, HDR).*

**Pioneer** 2255, 2192, 2281  
**Denon** 2310, 2311, 2312  
**Hitachi** 2307, 2308, 2309  
**JVC** 2290, 2291, 2293, 2294, 2295, 2296  
**LG** 2286, 2287  
**Marantz** 2302, 2303  
**Mitsubishi** 2300, 2301  
**Onkyo** 2289  
**Panasonic** 2277, 2278, 2279, 2280  
**Philips** 2280  
**Samsung** 2282  
**Sharp** 2304, 2305, 2306  
**Sony** 2283, 2284, 2285, 2292  
**Toshiba** 2288, 2282  
**Yamaha** 2291, 2298, 2299

## DVR (BDR, HDR)

*If operations are not possible using the preset codes below, you may be able to conduct operations with the preset codes for the DVD, BD.*

**Pioneer** 2257, 2193, 2258, 2259, 2260, 2261, 2264, 2265, 2266, 2270  
**Panasonic** 2263, 2269  
**Sharp** 2267, 2275  
**Sony** 2268, 2271, 2272, 2273, 2276  
**Toshiba** 2274

## VCR

**Pioneer** 1053, 1108  
**ABS** 1017  
**Adventura** 1005  
**Aiwa** 1005  
**Alienware** 1017  
**American High** 1004  
**Asha** 1002  
**Audio Dynamics** 1000  
**Audiovox** 1003  
**Bang & Olufsen** 1032  
**Beaumarck** 1002

**Bell & Howell** 1001  
**Calix** 1003  
**Candle** 1002, 1003  
**Canon** 1004  
**Citizen** 1002, 1003  
**Clorlyme** 1000  
**Craig** 1002, 1003  
**Curtis Mathes** 1000, 1002, 1004  
**Cybernex** 1002  
**CyberPower** 1017  
**Daewoo** 1005  
**DBX** 1000  
**Dell** 1017  
**DIRECTV** 1016, 1020, 1022, 1023, 1024, 1027, 1030, 1031  
**Dish Network** 1029  
**Dishpro** 1029  
**Durabrand** 1018  
**Dynatech** 1005  
**Echostar** 1029  
**Electrohome** 1003  
**ElectroPhonic** 1003  
**Emerson** 1003, 1004, 1005  
**ExpressVu** 1029  
**Fisher** 1001  
**Fuji** 1004  
**Funai** 1005  
**Gairard** 1005  
**Gateway** 1017  
**GE** 1002, 1004  
**GOI** 1029  
**Goldstar** 1000, 1003  
**Gradiente** 1005  
**Harley Davidson** 1005  
**Harman/Kardon** 1000  
**Headquarter** 1001  
**Hewlett Packard** 1017  
**HNS** 1016  
**Howard Computers** 1017  
**HP** 1017  
**HTS** 1029  
**Hughes Network Systems** 1016, 1020, 1022, 1023, 1024  
**Humax** 1016, 1020  
**Hush** 1017  
**iBUYPOWER** 1017  
**Instant Replay** 1004  
**JC Penney** 1000, 1001, 1002, 1003, 1004  
**JCL** 1004  
**JVC** 1000, 1001, 1020, 1029  
**Kenwood** 1000, 1001  
**Kodak** 1003, 1004  
**LG** 1003  
**Linksys** 1017  
**Lloyd's** 1005  
**LXI** 1003  
**Magnavox** 1004, 1018  
**Magnin** 1003  
**Marantz** 1000, 1001, 1004

**Marta** 1003  
**Media Center PC** 1017  
**MEI** 1004  
**Memorex** 1001, 1002, 1003, 1004, 1005, 1018, 1019  
**MGN Technology** 1002  
**Microsoft** 1017  
**Mind** 1017  
**Mitsubishi** 1010  
**Motorola** 1004  
**MTC** 1002  
**Multitech** 1002, 1005  
**NEC** 1000, 1001  
**Nikko** 1003  
**Niveus Media** 1017  
**Noblex** 1002  
**Northgate** 1017  
**Olympus** 1004  
**Optimus** 1003  
**Orion** 1014, 1019  
**Panasonic** 1004, 1008  
**Philco** 1004  
**Philips** 1004, 1011, 1016, 1020, 1022, 1023, 1024, 1025  
**Philips Magnavox** 1011  
**Pilot** 1003  
**Proscan** 1030  
**Pulsar** 1018  
**Quarter** 1001  
**Quartz** 1001  
**Quasar** 1004  
**Radio Shack** 1003  
**Radio Shack/Realistic** 1001, 1002, 1003, 1004, 1005  
**Radix** 1003  
**Randex** 1003  
**RCA** 1002, 1004, 1007, 1016, 1020, 1022, 1030, 1031  
**Realistic** 1001, 1002, 1003, 1004, 1005  
**ReplayTV** 1026  
**Ricavision** 1017  
**Runco** 1018  
**Samsung** 1002, 1016, 1022, 1024  
**Sanky** 1018  
**Sansui** 1014, 1019  
**Sanyo** 1001, 1002  
**Sears** 1001, 1003, 1004  
**Sharp** 1012  
**Shogun** 1002  
**Singer** 1004  
**Sonic Blue** 1026  
**Sony** 1006, 1009, 1017, 1021  
**Stack** 1017  
**ST5** 1004  
**Sylvania** 1004, 1005  
**Symphonic** 1005  
**Systemax** 1017  
**Tagar Systems** 1017  
**Tandy** 1001

**Tashiko** 1003  
**Teac** 1005  
**Technics** 1004, 1004, 1005  
**Tekno** 1003, 1004, 1005  
**Tivo** 1016, 1020, 1021, 1022, 1025  
**TMK** 1002  
**Toshiba** 1015, 1017, 1028  
**Totevision** 1002, 1003  
**Touch** 1017  
**UltimateTV** 1031  
**Ultitech** 1002  
**Vector Research** 1000  
**Video Concepts** 1000  
**VideoSonic** 1002  
**Visionic** 1017  
**Voodoo** 1017  
**Wards** 1002, 1003, 1004, 1005  
**XR-1000** 1004, 1005  
**Yamaha** 1000, 1001  
**Zenith** 1013, 1018  
**ZT Group** 1017

### Satellite Set Top Box

**Pioneer** 6097, 6098  
**ADB** 6035, 6001  
**Akai** 6102  
**Alba** 6005, 6011, 6013  
**Panasonic** 6008, 6009, 6030  
**Almtch** 6011  
**Amstrad** 6033, 6030, 6044  
**Antron** 6013  
**Asat** 6102  
**Austar** 6000, 6045  
**Bell ExpressVu** 6002, 6003  
**British Sky Broadcasting** 6030  
**Canal** 6105  
**Chaparal** 6034  
**CNS** 6001  
**Coolsat** 6021  
**Crossdigital** 6043  
**Digenius** 6104  
**Digiwave** 6053  
**DirectTV** 6070, 6110, 6111, 6062, 6063, 6113, 6008, 6038, 6054, 6069, 6060, 6059, 6043, 6018, 6114, 6115, 6116, 6093  
**Dish Network System** 6002, 6089, 6003, 6004  
**Dishpro** 6002, 6089, 6004  
**Echostar** 6002, 6089, 6036, 6005, 6003, 6004  
**ExpressVu** 6002, 6004  
**Fortec Star** 6123, 6023  
**Fresat** 6014  
**Funai** 6070  
**GE** 6111  
**General Instrument** 6032  
**GOI** 6002, 6004

**Grundig** 6007, 6030  
**Hirschmann** 6033  
**Hisense** 6020  
**Hitachi** 6038, 6049  
**Houston** 6002  
**HTS** 6002, 6004  
**Hughes Network Systems** 6113, 6038, 6054, 6114, 6115, 6116  
**Hyundai** 6016  
**ilo** 6020  
**Innova** 6059  
**Jerrold** 6032  
**JVC** 6002, 6003, 6004  
**Kathrein** 6096  
**Lava** 6053  
**LG** 6047, 6018  
**Marantz** 6102  
**McIntosh** 6032  
**Mitsubishi** 6038  
**Motorola** 6032, 6042  
**NEC** 6050  
**Netsat** 6059  
**Next Level** 6032  
**nfusion** 6015  
**Nokia** 6025, 6026, 6118, 6119, 6121  
**Pace** 6035, 6005, 6030, 6031  
**Panarex** 6016  
**Panasonic** 6008, 6009, 6030  
**Pansat** 6016, 6022  
**Philips** 6002, 6113, 6038, 6054, 6060, 6059, 6102, 6103, 6030, 6114  
**Primestar** 6032  
**Proscan** 6110, 6111  
**Proton** 6020  
**RadioShack** 6002, 6111, 6032  
**Radix** 6036  
**RCA** 6002, 6110, 6111, 6113, 6102, 6061, 6114  
**Saba** 6014  
**Sagem** 6041, 6120  
**Samsung** 6070, 6113, 6091, 6043, 6017, 6114, 6093  
**Sanyo** 6046  
**Sat Cruiser** 6015  
**Schwaiger** 6066  
**Siemens** 6007, 6036  
**SKY** 6042, 6059, 6030, 6031  
**SM Electronic** 6011  
**Sony** 6051  
**Sonicview** 6055, 6107  
**Sony** 6082, 6063, 6030  
**Star Choice** 6032  
**Star Trak** 6032  
**TechniSat** 6033  
**Thomson** 6110, 6111, 6014  
**Tivo** 6113, 6114, 6115, 6116  
**Toshiba** 6038, 6054, 6039  
**TPS** 6041

**Triasat** 6033  
**Ultrasat** 6021  
**US Digital** 6020  
**USDTV** 6020  
**ViewSat** 6048  
**Voom** 6032  
**Zehnder** 6101  
**Zenith** 6042, 6069, 6037

### Satellite Set Top Box (SAT/PVR Combination)

**Bell ExpressVu** 6002, 6003  
**DirectTV** 6070, 6110, 6062, 6113, 6060, 6059, 6114, 6115, 6116  
**Dish Network System** 6002, 6089  
**Dishpro** 6002, 6089  
**Echostar** 6002, 6089, 6003  
**ExpressVu** 6002  
**Hughes Network Systems** 6113, 6114, 6115, 6116  
**JVC** 6003  
**Motorola** 6032  
**Philips** 6113, 6114  
**Proscan** 6110  
**Samsung** 6114  
**Sonicview** 6055, 6107  
**Sony** 6062  
**Star Choice** 6032  
**Tivo** 6113, 6114, 6115, 6116

### Cable Set Top Box

**Pioneer** 6029, 6028, 6095, 6099, 0297  
**ABC** 6122  
**Accuphase** 6122  
**Amino** 6077, 6078  
**Auna** 6082  
**BCC** 6072  
**Bell & Howell** 6122  
**Bright House** 6074, 6029  
**Cable One** 6074, 6029  
**Cablevision** 6074, 6029  
**Charter** 6074, 6029, 6058  
**Cisco** 6029, 6028, 6083  
**Comcast** 6074, 6029, 1982  
**Cox** 6074, 6029  
**Digeo** 6029, 6058  
**Director** 6073  
**Emerson** 6122  
**Fosgate** 6072  
**General Instrument** 6073, 6072, 6122  
**Homecast** 6024  
**i3 Micro** 6077  
**Insight** 6074, 6073, 6029  
**Jebsee** 6122

**Jerrold** 6073, 6072, 6122  
**Knology** 6029  
**Macab** 6040  
**Mediacom** 6074, 6029  
**Memorex** 6112  
**Motorola** 6074, 6073, 6072, 6029, 6122, 6094  
**MTS** 6094  
**Myrio** 6077, 6078  
**Noos** 6040  
**Pace** 6074, 6029, 6028, 6106, 6083  
**Panasonic** 6112, 6083  
**Paragon** 6112  
**Penney** 6112  
**Philips** 6012  
**Pulsar** 6112  
**Quasar** 6112  
**Regal** 6072  
**Rogers** 6029  
**Runco** 6112  
**Samsung** 6095  
**Scientific Atlanta** 6029, 6028, 6027, 6112  
**Sejin** 6077  
**Shaw** 6074  
**Starcom** 6122  
**Stargate** 6122  
**Suddenlink** 6074, 6029  
**Supercable** 6072  
**Time Warner** 6074, 6029, 6058  
**Tivo** 6076  
**Toshiba** 6112  
**United Cable** 6072, 6122  
**US Electronics** 6072  
**Viewday** 6112  
**Zenith** 6112

### Cable Set Top Box (Cable/PVR Combination)

**Pioneer** 6029  
**Amino** 6078  
**Bright House** 6074, 6029  
**Cable One** 6074, 6029  
**Cablevision** 6074, 6029  
**Charter** 6074, 6029, 6058  
**Cisco** 6029, 6083  
**Cisco** 6029, 6083  
**Comcast** 6074, 6029, 6083, 6076  
**Cox** 6074, 6029  
**Digeo** 6016, 6058  
**Homecast** 6024  
**Insight** 6074, 6029  
**Knology** 6029  
**Mediacom** 6074, 6029  
**Motorola** 6074, 6081  
**Myrio** 6078  
**Pace** 6029

**Panasonic** 6083  
**Rogers** 6029  
**Scientific Atlanta** 6029  
**Shaw** 6074  
**Suddenlink** 6074, 6029  
**Supercable** 6072  
**Time Warner** 6074, 6029, 6058  
**Tivo** 6076

### CD

**Pioneer** 5000, 5011  
**AKAI** 5043  
**Asuka** 5045  
**Denon** 5019  
**Fisher** 5048  
**Goldstar** 5040  
**Hitachi** 5042  
**Kenwood** 5020, 5021, 5031  
**Luxman** 5049  
**Marantz** 5033  
**Onkyo** 5017, 5018, 5030, 5050  
**Panasonic** 5036  
**Philips** 5022, 5032, 5044  
**RCA** 5013, 5029  
**Roadstar** 5062  
**Sharp** 5051  
**Sony** 5012, 5023, 5026, 5027, 5028, 5039  
**TEAC** 5015, 5016, 5034, 5035, 5037  
**Technics** 5041  
**Victor** 5014  
**Yamaha** 5024, 5025, 5038, 5046, 5047

### CD-R

**Pioneer** 5001, 5053  
**Philips** 5054  
**Yamaha** 5055

### Tuner

**Pioneer** 5060

### Laser Disc Player

**Pioneer** 5002, 5003

### Cassette Deck

**Pioneer** 5058, 5059

### Digital Tape

**Pioneer** 5057

### MD

**Pioneer** 5056

## Chapter 10: Additional information

### Troubleshooting

Incorrect operations are often mistaken for trouble and malfunctions. If you think that there is something wrong with this component, check the points below. Take a look at the other components and electrical appliances being used, because sometimes the problem may lie there. If the trouble isn't sorted out even after going through the checks below, ask your nearest Pioneer authorized independent service company to carry out repair work.

- If the unit does not operate normally due to external effects such as static electricity disconnect the power plug from the outlet and insert again to return to normal operating conditions.

### General

#### The power does not turn on.

- Disconnect the power plug from the outlet, and insert again.
- Make sure there are no loose strands of speaker wire touching the rear panel. This could cause the receiver to shut off automatically.

#### Power cannot be turned off. (ZONE2 ON is displayed.)

- Press the **RECEIVER** button, then with the **SHIFT** button pressed, press the **RECEIVER** button to switch the sub zone off.

#### The receiver suddenly switches off.

- When the Auto Power Down function is working, the power will automatically turn off if the receiver has not operated for several hours. Check the setting for the Auto Power Down function (see *The Auto Power Down menu* on page 42).
- After about a minute (you won't be able to switch the unit on during this time), switch the receiver back on. If the message persists, call a Pioneer authorized independent service company.

#### The power suddenly turns on or off, or the input suddenly changes (When the Control with HDMI is ON).

- This happens because of the synchronized operation due to the **Control** with HDMI function. If synchronized operations are not needed, set the **Control** with HDMI to **OFF** (see *HDMI Setup* on page 43).

#### OVERHEAT shows in the display and the power turns off.

- The temperature within the unit has exceeded the allowable value. Try moving the unit for better ventilation (see page 2).
- Lower the volume level.

#### TEMP shows in the display and the volume level drops.

- The temperature within the unit has exceeded the allowable value. Try moving the unit for better ventilation (see page 2).
- Lower the volume level.

#### No sound is output when an input function is selected.

- Use **MASTER VOLUME** to turn up the volume.
- Press **MUTE** on the remote control to turn muting off.
- Press **SPEAKERS** to select the proper speaker set (see *Switching the speaker terminal* on page 12).
- Set the **SIGNAL SEL** to **H** (HDMI), **C1/O1/O2** (digital) or **A** (analog) according to the type of connections made (refer to page 26).
- Make sure the component is connected correctly (refer to *Connecting your equipment* on page 10).
- Check the audio output settings of the source component.
- Refer to the instruction manual supplied with the source component.

#### No image is output when an input function is selected.

- Make sure the component is connected correctly (refer to *Connecting your equipment* on page 10).
- Check *The Input Assign menu* on page 40 to make sure you're assigned the correct input.
- The video input selected on the TV monitor is incorrect. Refer to the instruction manual supplied with the TV.
- For HDMI, or when Video Converter is set to **OFF** and a TV and another component are connected with different cords (in *Video Converter* on page 41), you must connect your TV to this receiver using the same type of video cable as you used to connect your video component.
- Some components (such as video game units) have resolutions that may not be converted. If adjusting this receiver's Resolution setting (in *Resolution* on page 41) and/or the resolution settings on your component or display doesn't work, try switching Video Converter (in *Video Converter* on page 41) **OFF**.

#### No sound from subwoofer.

- Make sure the subwoofer is switched on.
- If the subwoofer has a volume knob, make sure it's turned up.
- The Dolby Digital or DTS source you are listening to may not have an LFE channel.
- Switch the subwoofer setting in *Speaker Setting* on page 38 to **YES** or **PLUS**.

- Switch the **LFE ATT** (*LFE Attenuate*) on page 36 to **LFEATT 0** or **LFEATT 5**.

#### No sound from surround or center speakers.

- Connect the speakers properly (refer to page 12).
- Refer to *Speaker Setting* on page 38 to check the speaker settings.
- Refer to *Channel Level* on page 39 to check the speaker levels.

#### The Phase Control feature doesn't seem to have an audible effect.

- If applicable, check that the lowpass filter switch on your subwoofer is off, or the lowpass cutoff is set to the highest frequency setting. If there is a PHASE setting on your subwoofer, set it to 0° (or depending on the subwoofer, the setting where you think it has the best overall effect on the sound).
- Make sure the speaker distance setting is correct for all speakers (see *Speaker Distance* on page 40).

#### Considerable noise in radio broadcasts.

- Connect the antenna (page 20) and adjust the position for best reception.
- Route any loose cables away from the antenna terminals and wires.
- Fully extend the FM wire antenna, position for best reception, and secure to a wall (or connect an outdoor FM antenna).
- Connect an additional internal or external AM antenna (page 21).
- Turn off equipment causing interference or move it away from the receiver (or move antennas farther away from equipment causing noise).

#### Broadcast stations cannot be selected automatically.

- Connect an outdoor antenna (refer to page 21).

#### Noise during playback of a cassette deck.

- Move the cassette deck away from your receiver, until the noise disappears.

#### No sound is output or a noise is output when software with DTS is played back.

- Make sure the player's settings are correct and/or the DTS signal out is on. Refer to the instruction manual supplied with the DVD player.

#### There seems to be a time lag between the speakers and the output of the subwoofer.

- See *Automatically setting up for surround sound (MCACC)* on page 24 to set up your system again using MCACC (this will automatically compensate for a delay in the subwoofer output).

**After using the Auto MCACC setup, the speaker size setting (LARGE or SMALL) is incorrect.**

- Low-frequency noise could have been caused by an air conditioner or motor. Switch off all appliances in the room and rerun the Auto MCACC setup.

**Can't operate the remote control.**

- Replace the batteries (refer to page 9).
- Operate within 7 m (23 ft.), 30° of the remote sensor (refer to page 9).
- Remove the obstacle or operate from another position.
- Avoid exposing the remote sensor on the front panel to direct light.

**The display is dark or off.**

- Press **DIMMER** on the remote control repeatedly to return to the default.

**Display blinks 12V ERR.**

- An error has arisen in the 12 V trigger jack. Reconnect accurately then turn the power back on.

**The receiver doesn't recognize iPod touch/iPhone.**

- Try the following.
  1. Simultaneously keep pressing the sleep button and home button on the iPod touch or iPhone for over 10 seconds to restart.
  2. Turn on the receiver.
  3. Connect the iPod touch/iPhone to the receiver.

**The Bluetooth wireless technology device cannot be connected or operated. Sound from the Bluetooth wireless technology device is not emitted or the sound is interrupted.**

- Check that no object that emits electromagnetic waves in the 2.4 GHz band (microwave oven, wireless LAN device or Bluetooth wireless technology apparatus) is near the unit. If such an object is near the unit, set the unit far from it. Or, stop using the object emitting the electromagnetic waves.
- Check that the Bluetooth wireless technology device is not too far from the unit and that obstructions are not set between the Bluetooth wireless technology device and the unit. Set the Bluetooth wireless technology device and the unit so that the distance between them is less than about 10 m (32 ft.) and no obstructions exist between them.
- Check that the Bluetooth ADAPTER and the ADAPTER PORT terminal of the unit are correctly connected.
- The Bluetooth wireless technology device may not be set to the communication mode supporting the Bluetooth wireless technology. Check the setting of the Bluetooth wireless technology device.

- Check that pairing is correct. The pairing setting was deleted from this unit or the Bluetooth wireless technology device. Reset the pairing.
- Check that the profile is correct. Use a Bluetooth wireless technology device that supports A2DP profile and AVRCP profile.

## HDMI

**No picture or sound.**

- If the problem still persists when connecting your HDMI component directly to your monitor, please consult the component or monitor manual or contact the manufacturer for support.

**No picture.**

- Depending in the output settings of the source component, it may be outputting a video format that can't be displayed. Change the output settings of the source, or connect using the component or composite jacks.
- This receiver is HDCP-compatible. Check that the components you are connecting are also HDCP-compatible. If they are not, please connect them using the component or composite video jacks.
- Depending on the connected source component, it's possible that it will not work with this receiver (even if it is HDCP-compatible). In this case, connect using the component or composite video jacks between source and receiver.
- If video images do not appear on your TV, try adjusting the resolution, Deep Color or other setting for your component.
- To output signals in Deep Color, use an HDMI cable (High Speed HDMI® Cable) to connect this receiver to a component or TV with the Deep Color feature.

**No sound, or sound suddenly ceases.**

- Check that the Audio Parameter setting is set to **HDMI AMP/THRU** (refer to page 36).
- If the component is a DVI device, use a separate connection for the audio.
- HDMI format digital audio transmissions require a longer time to be recognized. Due to this, interruption in the audio may occur when switching between audio formats or beginning playback.
- Turning on/off the device connected to this unit's HDMI OUT terminal during playback, or disconnecting/connecting the HDMI cable during playback, may cause noise or interrupted audio.

**Synchronized operation not possible using Control with HDMI function.**

- Check the HDMI connections.
- The cable may be damaged.
- Select **ON** for the **Control** with HDMI setting (see *HDMI Setup* on page 43).
- Turn the TV's power on before turning on this receiver's power.
- Set the TV side Control with HDMI setting to on (see TV's operating instructions).

## Important information regarding the HDMI connection

There are cases where you may not be able to route HDMI signals through this receiver (this depends on the HDMI equipped component you are connecting-check with the manufacturer for HDMI compatibility information). If you aren't receiving HDMI signals properly through this receiver (from your component), please try the following configuration when connecting up.

### Configuration A

Use component video cables to connect the video output of your HDMI-equipped component to the receiver's component video input. The receiver can then convert the analog component video signal to a digital HDMI signal for transmission to the display. For this configuration, use the most convenient connection (digital is recommended) for sending audio to the receiver. See the operating instructions for more on audio connections.

#### Note

- The picture quality will change slightly during conversion.

### Configuration B

Connect your HDMI-equipped component directly to the display using an HDMI cable. Then use the most convenient connection (digital is recommended) for sending audio to the receiver. See the operating instructions for more on audio connections. Set the display volume to minimum when using this configuration.

**Note**

- Depending on the component, audio output may be limited to the number of channels available from the connected display unit (for example audio output is reduced to 2 channels for a monitor with stereo audio limitations).
- If you want to switch the input source, you'll have to switch functions on both the receiver and your display unit.
- Since the sound is muted on the display when using the HDMI connection, you must adjust the volume on the display every time you switch input sources.

**iPod messages****'iPod/USB Error 1 (I/U ERR1)'****'iPod/USB Error 3 (I/U ERR3)'**

→ Switch off the receiver and reconnect the iPod to the receiver. If this doesn't seem to work, try resetting your iPod.

**'iPod/USB Error 2 (I/U ERR2)'**

→ Switch off the receiver and reconnect the iPod to the receiver. If this doesn't seem to work, try resetting your iPod.

→ An iPod not supported by this receiver is connected. Connect the iPod supported by this receiver (see page 27).

**'No Track'**

→ When there are no tracks in the category selected on the iPod. Select a different category.

**USB messages****'iPod/USB Error 1 (I/U ERR1)'**

→ There is a problem with the signal path from the USB to the receiver. Switch off the receiver and reconnect the USB to the receiver.

**'iPod/USB Error 3 (I/U ERR3)'**

→ When there is no response from the USB. Switch off the receiver and reconnect the USB to the receiver.

**'iPod/USB Error 4 (I/U ERR4)'**

→ The power requirements of the USB device are too high for this receiver. Switch off the receiver and reconnect the USB to the receiver.

**SIRIUS radio messages****'NO ANT'**

→ Antenna is not properly connected. Check that the antenna cable is attached securely.

**'CHECK SIRIUS TUNER'**

→ SIRIUS Connect tuner is not properly connected. Check that the 8 pin mini DIN cable and AC Adapter are attached securely.

**'NO SIG'**

→ The SIRIUS signal is too weak at the current location. There is no SIRIUS signal or the SiriusConnect Tuner is connected.

**'SUB UPDT'**

→ Unit is updating subscription. Wait until the encryption code has been updated.

**'UPD \*\*\*%'**

→ Unit is updating channels. Wait until the encryption code has been updated.

**'INVLD CH'**

→ Selected channel is not available/does not exist. Select another channel.

**About iPod/iPhone/iPad**

Made for



iPod



iPhone



iPad

"Made for iPod," "Made for iPhone" and "Made for iPad" mean that an electronic accessory has been designed to connect specifically to iPod, iPhone, or iPad, respectively, and has been certified by the developer to meet Apple performance standards. Apple is not responsible for the operation of this device or its compliance with safety and regulatory standards. Please note that the use of this accessory with iPod, iPhone, or iPad may affect wireless performance.

*Apple, iPad, iPhone, iPod, iPod shuffle, iPod nano, iPod classic, iPod touch and iTunes are trademarks of Apple Inc., registered in the U.S. and other countries.*

**Resetting the main unit**

Use this procedure to reset all the receiver's settings to the factory default. Use the front panel controls to do this.

**1 Switch the receiver into standby.****2 While holding down BAND, press and hold STANDBY/ON for about two seconds.****3 When you see RESET? appear in the display, press AUTO SURROUND/STREAM DIRECT.**

**OK?** shows in the display.

**4 Press ALC/STANDARD SURR to confirm.**

**OK** appears in the display to indicate that the receiver has been reset to the factory default settings.

**Important**

- If the **Control** with HDMI function is set to **ON**, you may not be able to reset the unit. In this case, reset either by turning **OFF** the **Control** with HDMI function, or by putting the unit into standby mode by turning off the power of all the connected devices, and resetting after the HDMI indicator on the front panel turns off.



### Cleaning the unit

- Use a polishing cloth or dry cloth to wipe off dust and dirt.
- When the surface is dirty, wipe with a soft cloth dipped in some neutral cleanser diluted five or six times with water, and wrung out well, and then wipe again with a dry cloth. Do not use furniture wax or cleansers.
- Never use thinners, benzine, insecticide sprays or other chemicals on or near this unit, since these will corrode the surface.

### Specifications

#### Amplifier section

**Continuous average power output of 80 watts\* per channel, min., at 8 ohms, from 20 Hz to 20 000 Hz with no more than 0.08 %\*\* total harmonic distortion.**

Front (stereo) ..... 80 W + 80 W  
 Guaranteed speaker impedance ..... 6 Ω to 16 Ω  
 \* Measured pursuant to the Federal Trade Commission's Trade Regulation rule on Power Output Claims for Amplifiers  
 \*\* Measured by Audio Spectrum Analyzer

#### Audio Section

Input (Sensitivity/Impedance)  
 LINE ..... 200 mV/47 kΩ  
 Output (Level/Impedance)  
 REC ..... 200 mV/2.2 kΩ  
 Signal-to-Noise Ratio (IHF, short circuited, A network)  
 LINE ..... 98 dB  
 Signal-to-Noise Ratio [EIA, at 1 W (1 kHz)]  
 LINE ..... 79 dB

#### Video Section

Signal level  
 Composite ..... 1 Vp-p (75 Ω)  
 Component Video ..... Y: 1.0 Vp-p (75 Ω)  
 PB, PR: 0.7 Vp-p (75 Ω)  
 Corresponding maximum resolution  
 Component Video ..... 1080p (1125p)

#### Tuner Section

Frequency Range (FM) ..... 87.5 MHz to 108 MHz  
 Antenna Input (FM) ..... 75 Ω unbalanced  
 Frequency Range (AM) ..... 530 kHz to 1700 kHz  
 Antenna (AM) ..... Loop antenna

#### Digital In/Out Section

HDMI terminal ..... Type A (19-pin)  
 HDMI output type ..... 5 V, 100 mA  
 USB terminal ..... USB2.0 Full Speed (Type A)  
 iPod terminal ..... USB, and Video (Composite)  
 SIRIUS antenna cable ..... 8-pin mini DIN cable  
 ADAPTER PORT terminal ..... 5 V, 100 mA

#### Integrated control section

Control (IR) terminal ..... Ø 3.5 Mini-jack (MONO)  
 IR signal ..... High Active (High Level: 2.0 V)  
 12 V Trigger terminal ..... Ø 3.5 Mini-jack (MONO)  
 12 V Trigger output type ..... 12 V, 50 mA

#### Miscellaneous

Power Requirements ..... AC 120 V, 60 Hz  
 Power Consumption ..... 500 W  
 In standby ..... 0.4 W (Control OFF)  
 Dimensions ..... 435 mm (W) x 168 mm (H) x 362.5 mm (D)  
 17<sup>3</sup>/16 in. (W) x 6<sup>5</sup>/8 in. (H) x 14<sup>5</sup>/16 in. (D)  
 Weight (without package) ..... 9.6 kg (21 lb 3 oz)

#### Furnished Parts

Microphone (for Auto MCACC setup) ..... 1  
 Remote control ..... 1  
 Dry cell batteries (AAA size IEC R03) ..... 2  
 AM loop antenna ..... 1  
 FM wire antenna ..... 1  
 iPod cable ..... 1  
 These operating instructions

#### Note

- Specifications and the design are subject to possible modifications without notice, due to improvements.

Manufactured under license from Dolby Laboratories. "Dolby", "Pro Logic", "Surround EX", and the double-D symbol are trademarks of Dolby Laboratories.

Manufactured under license under U.S. Patent #'s: 5,451,942; 5,956,674; 5,974,380; 5,978,762; 6,226,616; 6,487,535; 7,212,872; 7,333,929; 7,392,195; 7,272,567 & other U.S. and worldwide patents issued & pending. DTS and the Symbol are registered trademarks, & DTS-HD, DTS-HD Master Audio, and the DTS logos are trademarks of DTS, Inc. Product includes software. © DTS, Inc. All Rights Reserved.

### The Safety of Your Ears is in Your Hands

Get the most out of your equipment by playing it at a safe level – a level that lets the sound come through clearly without annoying blaring or distortion and, most importantly, without affecting your sensitive hearing. Sound can be deceiving. Over time, your hearing "comfort level" adapts to higher volumes of sound, so what sounds "normal" can actually be loud and harmful to your hearing. Guard against this by setting your equipment at a safe level BEFORE your hearing adapts.

#### ESTABLISH A SAFE LEVEL:

- Set your volume control at a low setting.
- Slowly increase the sound until you can hear it comfortably and clearly, without distortion.
- Once you have established a comfortable sound level, set the dial and leave it there.

#### BE SURE TO OBSERVE THE FOLLOWING GUIDELINES:

- Do not turn up the volume so high that you can't hear what's around you.
- Use caution or temporarily discontinue use in potentially hazardous situations.
- Do not use headphones while operating a motorized vehicle; the use of headphones may create a traffic hazard and is illegal in many areas.





PIONEER ELECTRONICS (USA) INC.

PIONEER ELECTRONICS OF CANADA, INC.

**LIMITED WARRANTY**

WARRANTY VALID ONLY IN COUNTRY OF PRODUCT PURCHASE

**WARRANTY**

Pioneer Electronics (USA) Inc. (PUSA), and Pioneer Electronics of Canada, Inc. (POC), warrant that products distributed by PUSA in the U.S.A., and by POC in Canada that fail to function properly under normal use due to a manufacturing defect when installed and operated according to the owner's manual (reboxed) with the unit will be repaired or replaced with a unit of comparable value, at the option of PUSA or POC, without charge to you for parts or actual repair work. Parts supplied under this warranty may be new or rebuilt at the option of PUSA or POC.

**THIS LIMITED WARRANTY APPLIES TO THE ORIGINAL OR ANY SUBSEQUENT OWNER OF THIS PIONEER PRODUCT DURING THE WARRANTY PERIOD PROVIDED THE PRODUCT WAS PURCHASED FROM AN AUTHORIZED PIONEER DISTRIBUTOR/DEALER IN THE U.S.A. OR CANADA. YOU WILL BE REQUIRED TO PROVIDE A SALES RECEIPT OR OTHER VALID PROOF OF PURCHASE SHOWING THE DATE OF ORIGINAL PURCHASE OR, IF RENTED, YOUR RENTAL CONTRACT SHOWING THE PLACE AND DATE OF FIRST RENTAL. IN THE EVENT SERVICE IS REQUIRED, THE PRODUCT MUST BE DELIVERED WITHIN THE WARRANTY PERIOD. TRANSPORTATION PREPAID, AND FROM WITHIN THE COUNTRY OF PURCHASE AS EXPLAINED IN THIS DOCUMENT. YOU WILL BE RESPONSIBLE FOR REMOVAL AND INSTALLATION OF THE PRODUCT. PUSA OR POC, AS APPROPRIATE, WILL PAY TO RETURN THE REPAIRED OR REPLACEMENT PRODUCT TO YOU WITHIN THE COUNTRY OF PURCHASE.**

**PRODUCT WARRANTY PERIOD**

Home Audio and Video ..... Labor  
Microphones, Headphones, Photo Cartridges and Styluses ..... 1 Year 1 Year  
90 Days 90 Days

Shorter limited warranty periods apply to some models. Please refer to the limited warranty document enclosed with the product for a definitive statement of the warranty period. The warranty period for retail customers who rent the product commences upon the date product is first put into use (a) during the rental period or (b) retail sale, whichever occurs first.

**WHAT IS NOT COVERED**

**IF THIS PRODUCT WAS PURCHASED FROM AN UNAUTHORIZED DISTRIBUTOR, THERE ARE NO WARRANTIES, EXPRESS OR IMPLIED, INCLUDING THE IMPLIED WARRANTY OF MERCHANTABILITY AND THE IMPLIED WARRANTY OF FITNESS FOR A PARTICULAR PURPOSE, AND THIS PRODUCT IS SOLD STRICTLY "AS IS" AND "WITH ALL FAULTS". PIONEER SHALL NOT BE LIABLE FOR ANY CONSEQUENTIAL AND/OR INCIDENTAL DAMAGES.**

**PIONEER DOES NOT WARRANT ANY PRODUCT LISTED ABOVE WHEN IT IS USED IN A TRADE OR BUSINESS OR IN ANY INDUSTRIAL OR COMMERCIAL APPLICATION.**

**THIS WARRANTY DOES NOT COVER TELEVISION OR DISPLAY SCREENS DAMAGED BY STATIC, NON-MOVING, IMAGES APPLIED FOR LENGTHY PERIODS (BURN-IN).**

**THIS WARRANTY DOES NOT COVER THE CABINET OR ANY PARTS EXCEPT THE USER ATTACHED ANTENNA. ANY DAMAGE TO RECORDS OR RECORDING TAPES (BURN-IN), DAMAGE TO THE PRODUCT RESULTING FROM ALTERATIONS, MODIFICATIONS NOT AUTHORIZED IN WRITING BY PIONEER, ACCIDENT, MISUSE OR ABUSE, DAMAGE DUE TO LIGHTNING OR TOP SURGE SURGES, SUBSEQUENT DAMAGE FROM LEAKING, DAMAGE FROM INOPERATIVE BATTERIES, OR THE USE OF BATTERIES NOT CONFORMING TO THOSE SPECIFIED IN THE OWNER'S MANUAL.**

**THIS WARRANTY DOES NOT COVER THE COST OF PARTS OR LABOR WHICH WOULD BE OTHERWISE PROVIDED WITHOUT CHARGE UNDER THIS WARRANTY OBTAINED FROM ANY SOURCE OTHER THAN PIONEER AUTHORIZED SERVICE COMPANY OR THEIR DESIGNATED LOCATION. THIS WARRANTY DOES NOT COVER DEFECTS OR DAMAGE CAUSED BY THE USE OF UNAUTHORIZED PARTS OR LABOR OR FROM IMPROPER MAINTENANCE.**

**ALTERED, DEFACED, OR REMOVED SERIAL NUMBERS VOID THIS ENTIRE WARRANTY**

**NO OTHER WARRANTIES**

**IN THE U.S.A. - PIONEER LIMITS ITS OBLIGATIONS UNDER ANY IMPLIED WARRANTIES, INCLUDING, BUT NOT LIMITED TO, THE IMPLIED WARRANTIES OF MERCHANTABILITY AND FITNESS FOR A PARTICULAR PURPOSE TO A PERIOD NOT TO EXCEED THE WARRANTY PERIOD. NO WARRANTIES SHALL APPLY AFTER THE WARRANTY PERIOD. SOME STATES DO NOT ALLOW LIMITATIONS ON HOW LONG IMPLIED WARRANTY LASTS AND SOME STATES DO NOT ALLOW THE EXCLUSIONS OR LIMITATIONS OF INCIDENTAL OR CONSEQUENTIAL DAMAGES. SO THE ABOVE LIMITATIONS OR EXCLUSIONS MAY NOT APPLY TO YOU. THIS WARRANTY GIVES YOU SPECIFIC LEGAL RIGHTS AND YOU MAY HAVE OTHER RIGHTS WHICH MAY VARY FROM STATE TO STATE.**

**IN CANADA - EXCEPT AS EXPRESSLY PROVIDED HEREIN, THERE ARE NO REPRESENTATIONS, WARRANTIES OR OBLIGATIONS OR CONDITIONS, IMPLIED, STATUTORY OR OTHERWISE, APPLICABLE TO THIS PRODUCT.**

**TO OBTAIN SERVICE**

PUSA and POC have appointed a number of Authorized Service Companies throughout the U.S.A. and Canada should your product require service. To receive warranty service you need to present your sales receipt or, if rented, your rental contract showing place and date of original owner's transaction. If shipping the unit you will need to package it carefully and send it, transportation prepaid by a traceable, insured method, to an Authorized Service Company. Package the product using adequate padding material to prevent damage in transit. The original container is ideal for this purpose. Include your name, address and telephone number where you can be reached during business hours. On all complaints and concerns in the U.S.A. call Customer Support at 1-800-421-1404, or, in Canada, call Customer Satisfaction at 1-877-283-5901.

**IN THE U.S.A.**

For hook-up and operation of your unit or to locate an Authorized Service Company, please call or write:

PIONEER ELECTRONICS SERVICE, INC.  
P.O. BOX 1760  
LONG BEACH, CALIFORNIA 90801  
1-800-421-1404

<http://www.pioneerelectronics.com>

**IN CANADA**

For additional information on this warranty, please call or write:

CUSTOMER SATISFACTION GROUP  
PIONEER ELECTRONICS OF CANADA, INC.  
300 ALL STATE PARKWAY  
MARKHAM, ON L3R 0P2

(905) 479-4411  
1-877-283-5901  
<http://www.pioneerelectronics.ca>

**DISPUTE RESOLUTION**

**IN THE U.S.A.** - Following our response to any initial request to Customer Support, should a dispute arise between you and Pioneer, Pioneer makes available its Complaint Resolution Program to resolve the dispute. The Complaint Resolution Program is available to you, without charge. You are required to use the Complaint Resolution Program before you exercise any rights under, or seek any remedies, created by Title I of the Magnuson-Moss Warranty-Federal Trade Commission Improvement Act, 15 U.S.C. 2301 et seq. To use the Complaint Resolution Program call 1-800-421-1404 and explain to the customer service representative the problem you are experiencing, steps you have taken to have the product repaired during the warranty period and the name of the authorized distributor/dealer from whom the Pioneer product was purchased. After the complaint is resolved, you must respond to your complaint in writing informing you what action Pioneer will take, and in what time period, to resolve the dispute, or (2) respond to your complaint in writing informing you why it will not take any action.

**IN CANADA** - Call the Customer Satisfaction Manager at (905) 946-7446 to discuss your complaint and to obtain a prompt resolution.

RECORD THE PLACE AND DATE OF PURCHASE FOR FUTURE REFERENCE

Model No. \_\_\_\_\_  
Purchased From \_\_\_\_\_

Serial No. \_\_\_\_\_

Purchase Date \_\_\_\_\_

KEEP THIS INFORMATION AND YOUR SALES RECEIPT IN A SAFE PLACE

To register your product, find the nearest authorized service location, to purchase replacement parts, operating instructions, or accessories, please go to one of following URLs :

Pour enregistrer votre produit, trouver le service après-vente agréé le plus proche et pour acheter des pièces de rechange, des modes d'emploi ou des accessoires, reportez-vous aux URL suivantes :

**In the USA/Aux Etats-Unis**

<http://www.pioneerelectronics.com>

**In Canada/Aux Canada**

<http://www.pioneerelectronics.ca>

S018\_B1\_EnFr

Download an electronic version of this manual from our website.

© 2011 PIONEER CORPORATION.  
All rights reserved.

---

## **PIONEER CORPORATION**

1-1, Shin-ogura, Saiwai-ku, Kawasaki-shi, Kanagawa 212-0031, Japan

### **PIONEER ELECTRONICS (USA) INC.**

P.O. BOX 1540, Long Beach, California 90801-1540, U.S.A. TEL: (800) 421-1404

### **PIONEER ELECTRONICS OF CANADA, INC.**

340 Ferrier Street, Unit 2, Markham, Ontario L3R 2Z5, Canada TEL: 1-877-283-5901, 905-479-4411

### **PIONEER EUROPE NV**

Haven 1087, Keetberglaan 1, B-9120 Melsele, Belgium TEL: 03/570.05.11

### **PIONEER ELECTRONICS ASIACENTRE PTE. LTD.**

253 Alexandra Road, #04-01, Singapore 159936 TEL: 65-6472-7555

### **PIONEER ELECTRONICS AUSTRALIA PTY. LTD.**

5 Arco Lane, Heatherton, Victoria, 3202, Australia, TEL: (03) 9586-6300

### **PIONEER ELECTRONICS DE MEXICO S.A. DE C.V.**

Bldv.Manuel Avila Camacho 138 10 piso Col.Lomas de Chapultepec, Mexico, D.F. 11000 TEL: 55-9178-4270

K002\_B3\_En